

# ***Yamato***<sup>®</sup>

## Instruction manual

COMPUTERIZED ACCURATE  
TAPE TENSION CONTROLLER

# ACCU-10

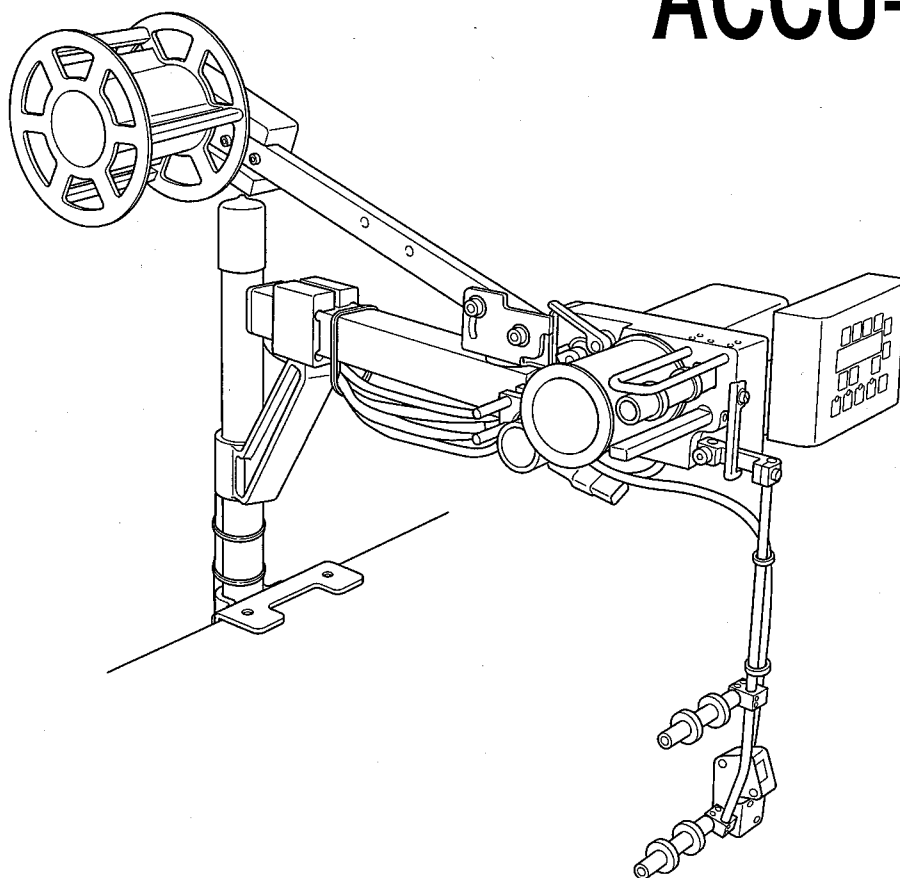











Thank you for having purchased the Model ACCU-10.  
Before using your ACCU-10, please read the instruction  
manual and understand the contents well.  
After reading the instruction manual, please keep it in a  
location where it is easily accessible to the operator.



**YAMATO SEWING MACHINE MFG. CO., LTD.**

# Contents

Safety instructions	i – iv
<b>1. Introduction</b>	<b>1</b>
1.1 Functions	1
1.2 Description of ACCU-10 types	1
1.3 Name of each part	2
<b>2. Installation</b>	<b>4</b>
2.1 Assembling poles	4
2.2 Installation of control box	5
2.3 Installing parts	6
2.4 Adjusting installation position	8
2.5 Wiring	10
2.6 When tape can not be fed straightly	11
2.7 Installation of other parts	12
 <b>3. Proper operation</b>	<b>16</b>
3.1 Process shifting switch	16
3.2 Process indicator	16
3.3 Passing tape	17
3.4 Tension free switch, c. set	18
3.5 Cutter switch (Extra parts)	19
<b>4. Operating control panel</b>	<b>20</b>
4.1 Name of each part	20
4.2 Display processes	21
4.2.1 Setting tension	21
4.2.2 Setting code	22
4.2.3 Setting size	23
4.3 Changing mode	23
 4.4 Setting examples	24
 4.5 Key lock	29
 4.6 Reset switch	29
 4.7 Automatic tape feeding	30
 4.7.1 Setting detection level	30
 4.7.2 Setting feeding amount	30
4.8 Convenient functions	31
 4.8.1 Learning function (Teaching mode)	31
 4.8.2 Mode copy function	32
 4.8.3 Combining modes	33
4.8.4 Setting distangle roller	35
4.8.5 Using function of detecting tape seams and knots	36
4.8.6 Correcting detection level for tape seams and knots	37

# Contents

4.9	Controlling devices on sewing machine	37
4.9.1	List of cutter device functions	38
4.9.2	List of tension releaser functions	38
4.9.3	List of thread chain trimmer functions	39
4.9.4	List of lint suction device functions	39
4.9.5	List of other functions	39
4.9.6	Function of linking with AZ8451	40
4.10	Adjusting tension when presser foot is up	40
4.11	Control functions	41
4.12	Connection test	42
4.12.1	Input test	42
4.12.2	Output test	42
<b>5.</b>	<b>Trouble shooting</b>	<b>43</b>
<b>6.</b>	<b>Specifications</b>	<b>44</b>
<b>7.</b>	<b>Information</b>	<b>45</b>
7.1	Description of connectors and input signals	45
7.2	Connecting AZ8451 with ACCU-10-CIT device	46

## Attention

◇ This instruction manual is designed mainly for technicians, but it is advisable that also operators read the instructions with  mark to use the machine properly.

◇ The numbers in lower left corners of figures are figure numbers. We use them in texts as needed for your reference.

## Attention

The parts used for this product are subject to change without notice. If such a change is made, any part of the contents and illustrations of this instruction manual may not conform to this product. In preparing the instruction manual, we have made our best efforts for making it free of any error or omission. If any error or omission should yet be found, it might not be rectified immediately.



# Safety instructions



## 1. To ensure safe use

Always observe the following instructions to ensure the safe use of the industrial sewing machines and devices.

### 1-1 Application and purpose

The sewing machine is designed to improve productivity in the sewing industry and must not be used for other applications and purposes. Do not use this sewing machine until it can be confirmed that safety measures for the drive units have been taken.

### 1-2 Before use

Read all instruction manuals thoroughly before starting the use of this machine and follow them.

Also, read the instruction manual for the installed drive unit.

### 1-3 Working environment

DO NOT WORK IN THE FOLLOWING ENVIRONMENTS:

- Place where atmosphere temperature and humidity give a bad influence the performance of sewing machines.
- Outdoors and place where the sewing machines are exposed to sunlight directly.
- Atmosphere containing dust, corrosive gases or flammable gases.
- Place where voltage fluctuation exceeds  $\pm 10\%$  of the rated voltage.
- Place where power capacity necessary for the used motor specifications cannot be secured.
- Place where strong electric or magnetic fields are generated such as near large-output high frequency transmitters or high frequency welding machines.

### 1-4 Unpacking and transportation

- (1) Unpack from the top.
- (2) Never hold the parts near the needle or threading parts when removing the sewing machine head from the buffer of box.
- (3) When carrying the sewing machine head, have an assistant.
- (4) Pay attention not to get excessive impact or shock when moving the sewing machine

head with a pushcart.

## 2. Installation and preparation

### 2-1 Instruction and training

Operators and workers, who supervise, repair or maintain the machine head and machine unit, are required to have the adequate knowledge and operation skills to do the job safely. In order to establish such necessary conditions, it needs for the employer to plan and enforce the safety education and training to those workers.

### 2-2 Sewing table and motor

- (1) Prepare a machine table that has enough strength to withstand the weight of the sewing head and any reaction while operating.
- (2) Maintain a comfortable working environment with considering the lighting and the arrangement of sewing machine so that the operators can work smoothly.
- (3) When installing the control box and the related parts on the sewing machine, take care about the posture of the worker.
- (4) Install the drive unit correctly according to the instruction manual.

### 2-3 Wiring

- (1) Never connect the plug for power supply until assembly is finished.
- (2) Fix the connectors securely to the sewing machine head, motor, and electric apparatus.
- (3) Do not apply excessive force to the connection cords.
- (4) Connect the cords away from the driving parts.
- (5) Place the ground wire securely to the designated position on the machine head.

### 2-4 Before operation

- (1) Take care not to attach lubricant, silicone oil, and grease on the eyes or skin.



# Safety instructions



Keep them away from children.

- (2) Be sure to fill or drop lubrication oil before operating the sewing machine. Use the Yamato SF oil as specified.
- (3) Never put your hand under the needle or near the moving parts of the machine when turning on power supply switch.
- (4) When operating a new sewing machine, make sure the rotating direction of pulley agrees with the rotating-direction mark.

## 2-5 During operation

- (1) Be sure to operate the sewing machine with the safeguards such as belt cover, finger guard, and eye guard.
- (2) Never place the finger, hair or objects under the needle or close to the moving parts while operating the sewing machine.
- (3) Be sure to turn off the power supply switch when threading or replacing the needles.
- (4) Never place your hands close to the knives when operating the sewing machine with the trimming devices.
- (5) Be sure to turn off the power supply switch when terminating the sewing work or leaving the sewing machine.
- (6) If the sewing machine malfunctions, abnormal sound or smell something unusual while operating, be sure to turn off the power supply switch.

## 2-6 Removal

- (1) Turn off the power supply switch if removed or replaced any parts or during adjustment of sewing machine.
- (2) Do not pull the cord when removing the plug. Be sure to hold the plug itself.
- (3) A high voltage is applied inside the control box. Turn off the power supply switch and wait more than 5 minutes before opening the cover.

## 3. Maintenance, inspection, and repair

- (1) Follow the instruction manuals for maintenance, inspection, and repair.
- (2) Entrust the maintenance, inspection, and repair to specially trained personnel.
- (3) Be sure to turn off the power supply switch and make sure the sewing machine and motor completely stop before the maintenance, inspection, and repair. (If using a clutch motor, take care that the motor keeps turning for a while even after turning off the power supply switch.)
- (4) Do not modify the sewing machine by the customer's judgment.
- (5) Be sure to use original replacement parts for repairs or maintenance.

## 4. Caution signs and alert pictorial markings

This instruction manual contains the following caution signs and alert pictorial markings to prevent you from injuring yourself or the sewing machine from being damaged.

Please follow the instructions.

### 4-1 Meanings of caution signs

**WARNING** indicates potentially hazardous situations which, if not heeded, could result in death or serious injury to you and others.

**Caution** indicates hazardous situations which, if not heeded, may result in minor or moderate injury to you and others, or may result in machine damage.

**NOTE** is used to emphasize essential information.



# Safety instructions



## 4-2 Alert pictorial markings



This mark indicates the warning which, if not heeded, could result in death or Serious injury.

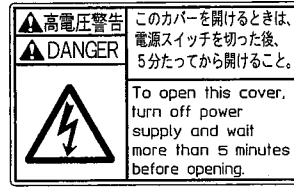

High-voltage applies in the control box. This label indicates that electric shock may be caused.



This mark indicates the caution for high temperature.



This label is affixed on the safeguards. Considering the operation, it is not affixed on the finger guard and eye guard. Be sure to operate with the finger guard and eye guard in position.



This mark indicates the warning which, if not heeded, could result in death or Serious injury.



Stepping motor and solenoid may overheat if used continuously. To prevent a burn, take care not to touch.



High-voltage applies in the control box. This label indicates that electric shock may be caused.



This mark indicates the caution which, if not grounded, the machine or device could malfunction and could result in personal injury.



If not connected earth line, static electricity may be generated and inflict injury on person. In addition, the malfunction of electric system may cause injury to person.

## 5. Warning labels on sewing machines

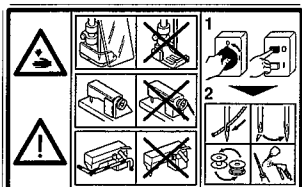

This label indicates that removal of the safeguards and works except for sewing performance while the power supply switch is on are prohibited. (For details, see the next page.)

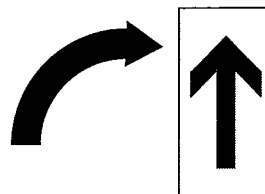



Check the rotating direction of machine pulley agrees with 'ROTATING-DIRECTION SYMBOL'.

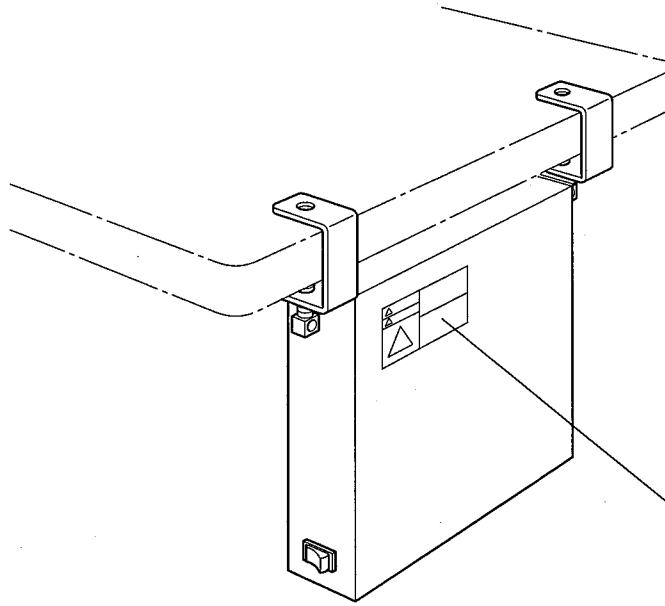

# Safety instructions



 高電圧警告	このカバーを開けるときは、電源スイッチを切った後、5分たってから開けること。
 DANGER	
	To open this cover, turn off power supply and wait more than 5 minutes before opening.

# 1 . Introduction

## 1.1 Functions

1. For common metering device, it controls the feeding amount of tape against the feeding amount of sewing machine. During sewing operation, the feeding amount of tape does not change, but the feeding amount of material changes slightly. This may cause uneven stitch as a result. ACCU-10 device controls the feeding amount of tape to keep the tension for tape fixed, so that a perfect sewing performance can be carried out.
2. For setting tension, 8 types of tension value can be input in one mode, and 50 modes can be memorized.
3. ACCU-10 can also control the following devices on sewing machine and motor function.
  - Air-operated fully automatic tape cutter
  - Thread chain suction (for thread chain cutter)
  - Presser foot lifter (air-operated)
  - Lint suction
  - Automatic motor stop function
4. The present process can proceed to the next process automatically after sewing preset stitch count, when using a rotation detector unit.  
And if a fabric detection switch is also equipped, the process can be shifted to the next automatically even at the beginning or the end of sewing.
5. The process shifting and the process proceeding can be monitored by process indicator.
6. The automatic tape feeding function (corresponding to YAMATO AEF) is included as standard.
7. The learning function, combining modes function, detecting tape seams and knots function and connection self test function are included as well.
8. We strongly recommend you to use this ACCU-10 device with Yamato sewing machines. The combination with other brands is also possible.

## 1.2 Description of ACCU-10 types

ACCU-10-A 1 T-3 0  
①        ② ③ ④ ⑤ ⑥

- |                                    |   |
|------------------------------------|---|
| ① Base type                        |   |
| ② Applicable sewing machines       | A: For interlock stitch sewing machine<br>B: For Zigzag stitch sewing machine<br>C: For overlock stitch sewing machine  |
| ③ Version number                   |   |
| ④ Installation position            | T: Tape feeding from top (Fig. 1-1)<br>S: Tape feeding from the right side (Fig. 1-2)<br>L: Tape feeding from bottom  |
| ⑤ Types of rotation detection unit | 0: None    1: Hall IC<br>2: Intermediate cable (for OEM motor)<br>3: Hall IC, pulley  |
| ⑥ Tension free switch              | 0: None<br>1: With presser foot lifter pedal (without presser foot lifter device)<br>2: With presser foot lifter device (for servo motor)<br>3: Knee lifter knee plate (for LG) |



# 1. Introduction

## 1.3 Name of each part

In case of ACCU-10-□□T

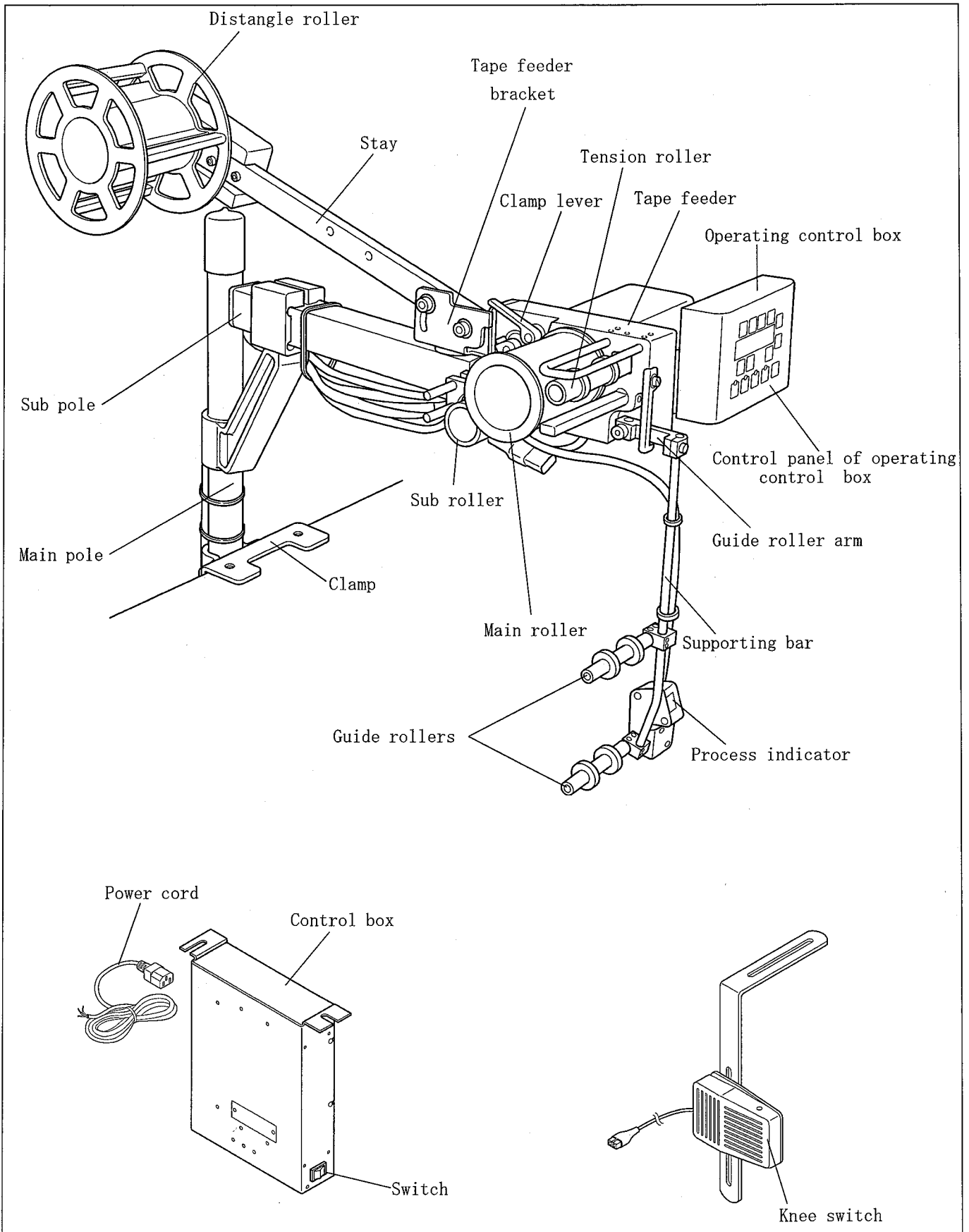

Fig. 1-1

In case of ACCU-10-□□S

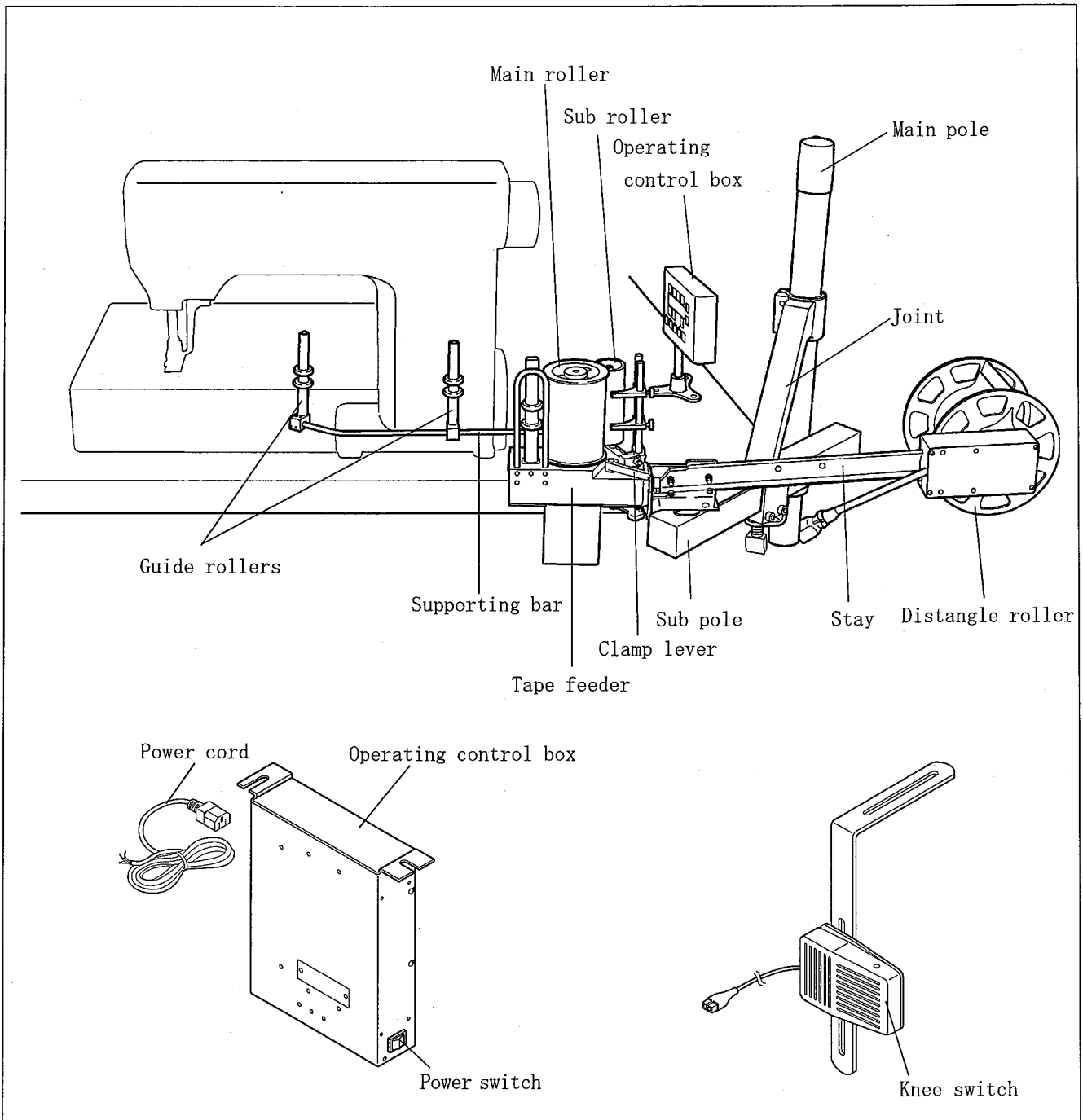

Fig. 1-2

# 2. Installation

For installation, the top feeding type ACCU-10-□□T is explained as an example.

For the parts according to the type of sewing machines and the installation positions, refer to "2.7 Installation of other parts".

For installing the right side feeding type, refer to Fig. 1-2.

## 2.1 Assembling poles

1. Fix the clamp ① onto the table with the bolts ②. (Fig. 2-1)

Insert a stick into the holes on the head of bolts ② respectively, and tighten them.

○The bolts for clamp ① can be installed from both up and down sides. (Fig. 2-1)

○The main pole ③ can be installed to a position the main pole ③ and the bolts ② of clamp don't obstruct sewing by changing the position of clamp (rear) ④.

2. Install the joint ⑤ onto the main pole ③ with the screws ⑥. (Fig. 2-2)

3. Install the main pole ③ onto the clamp ① with the screws ⑦. (Fig. 2-2)

4. Insert the sub pole ⑧ into the joint ⑤, and tighten the screws ⑨. (Fig. 2-3)

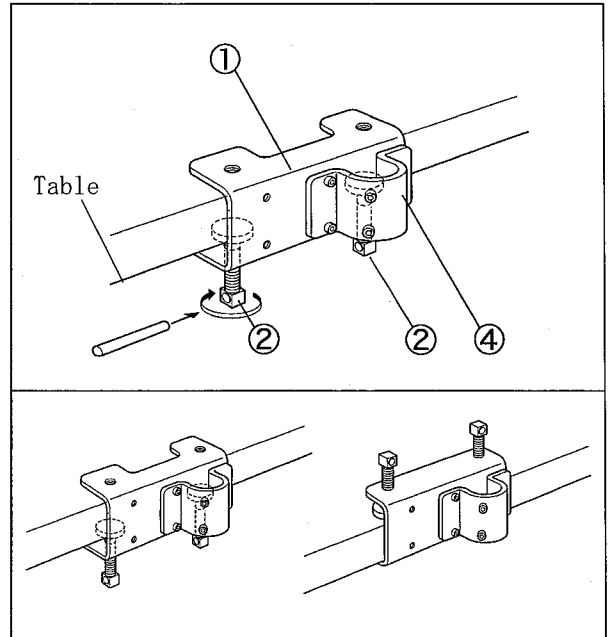

Fig. 2-1

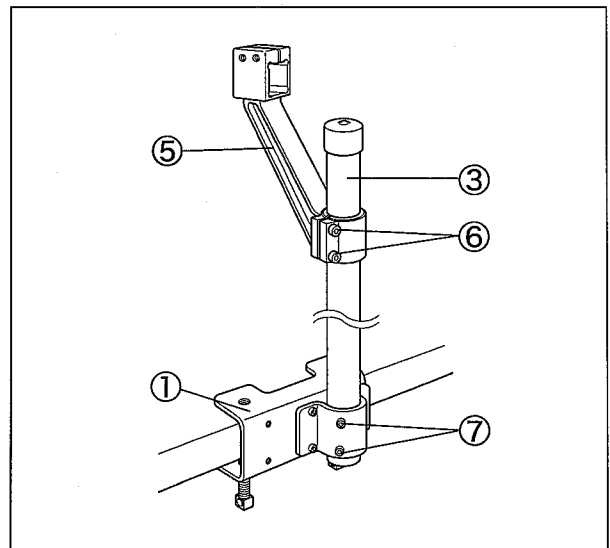

Fig. 2-2

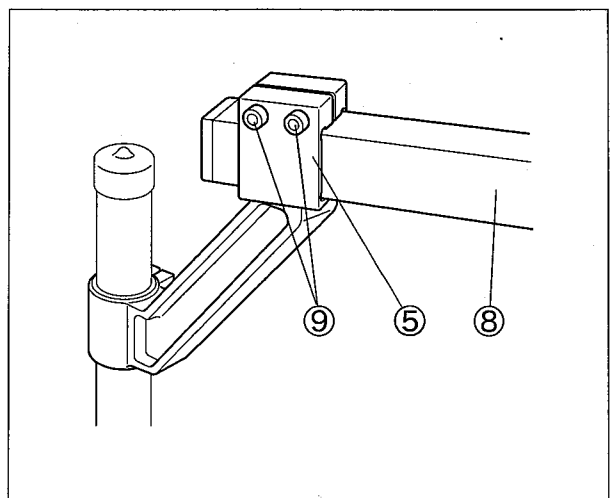

Fig. 2-3

## 2.2 Installation of control box

There are 3 ways to install the control box①.

1. Install it onto the bottom of the table with wood screws② directly. (Fig. 2-4)
2. Install it onto the bottom of the table with clamps (screws under the table), so that the control box can be removed easily. (Fig. 2-5, 2-7)
3. Install it onto the bottom of the table with clamps (screws above the table), so that the control box can be removed easily. (Fig. 2-6, 2-8)

Procedures for 2 and 3

1. Install the clamp③ onto the control box①.

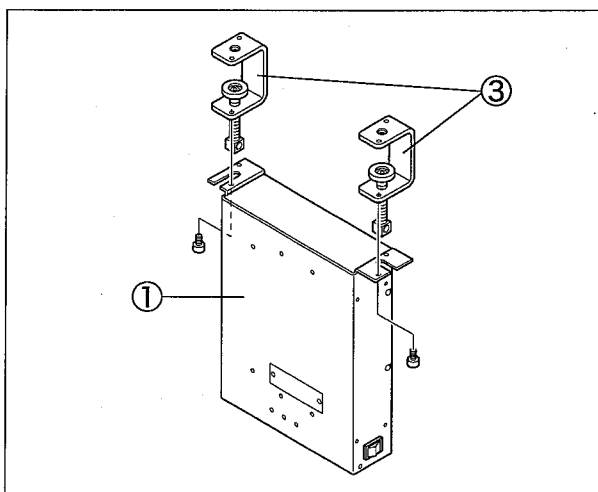

Fig. 2-5

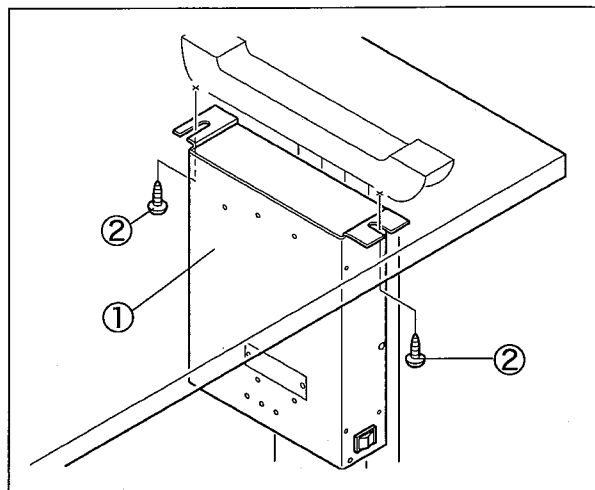

Fig. 2-4

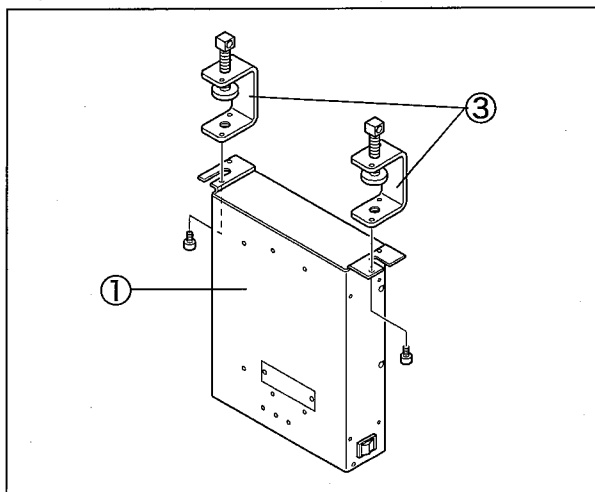

Fig. 2-6

2. Install the control box① onto the bottom of the table with the clamps③. Insert a stick into the holes on the head of screws④ respectively, and tighten them.

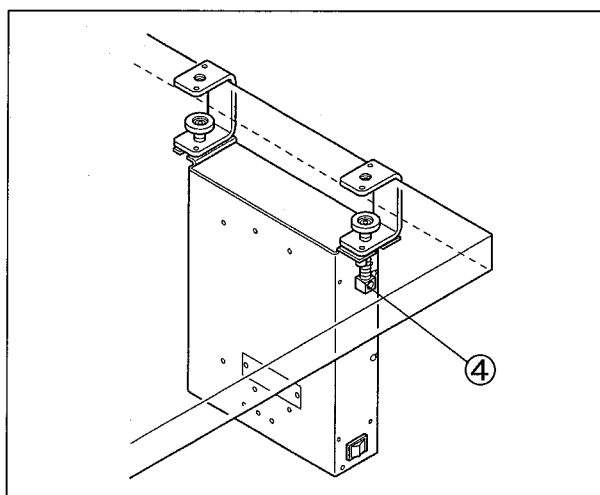

Fig. 2-7

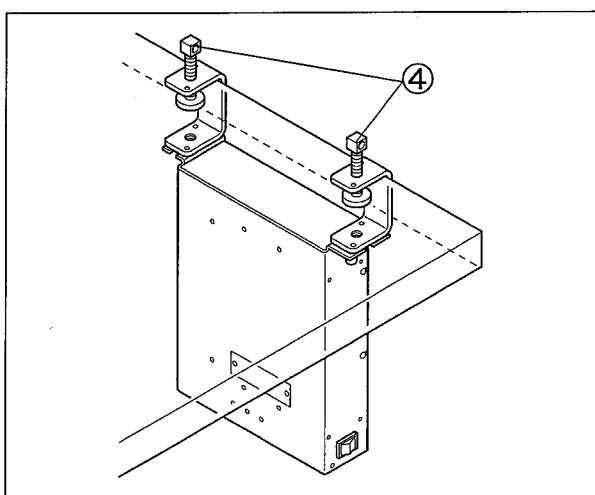

Fig. 2-8

## 2. Installation

### 2.3 Installing parts

1. Install the tape feeder<sup>③</sup> onto the tape feeder bracket<sup>④</sup> with the screw<sup>⑤</sup>.

Note: Lie the tape feeder down, when installing ACCU-10 to the right side of the sewing machine.

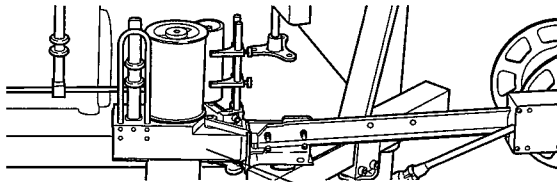

Fig. 2-10

Tape feeder

2. Install the operating control box<sup>⑥</sup> to the tape feeder<sup>③</sup> with the screws<sup>⑦</sup>. (Fig. 2-11)

Note: In case that want to install ACCU-10 to the right side of the sewing machine, set up a stand on the table and install the operating control box<sup>⑥</sup> onto the stand. The operating control box<sup>⑥</sup> can also be installed onto the upper cover of sewing machine. (Refer to Fig. 2-38.)

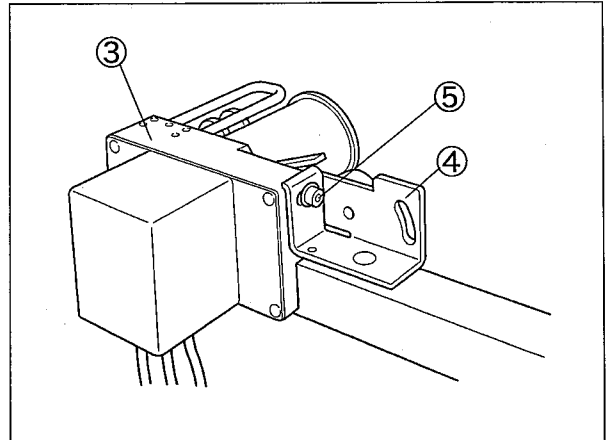

Fig. 2-9

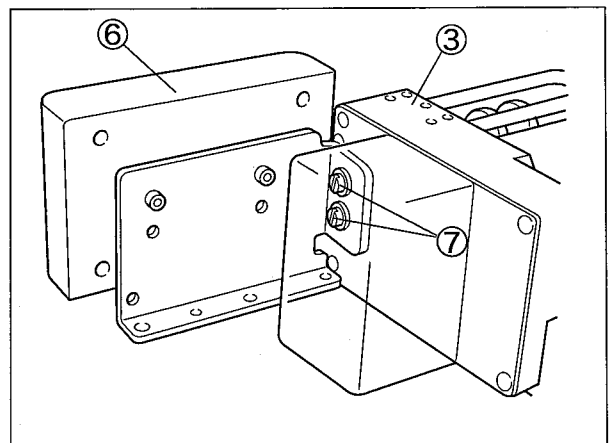

Fig. 2-11

3. Install the stay<sup>⑧</sup> to the tape feeder bracket<sup>④</sup> with the screws<sup>⑨</sup>. (Fig. 2-12)

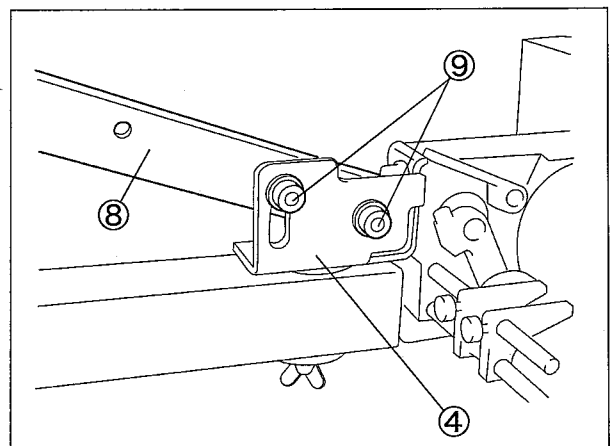

Fig. 2-12

4. Insert the supporting bar⑩ into the guide roller arm⑪ of the tape feeder③, and tighten the screw⑫. (Fig. 2-13)

Note: In case that want to install ACCU-10 to the right side of the sewing machine, remove the guide stopper⑬. Then, remove the process indicator⑭ and the switch holder⑮ from the supporting bar⑩. (Fig. 2-14)

For reinstalling the process indicator, refer to Fig. 2-40 in "2.7 Installation of other parts" .

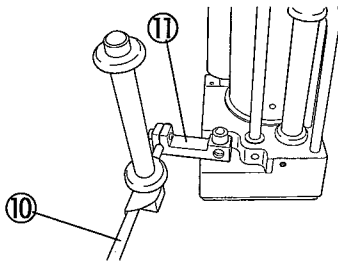

Fig. 2-14

5. Install the knee switch holder⑰ onto the bottom of the table with the wood screw⑱ by referring to Fig. 2-14. Then, install the knee switch (process shifting switch)⑯ onto the knee switch holder⑰.

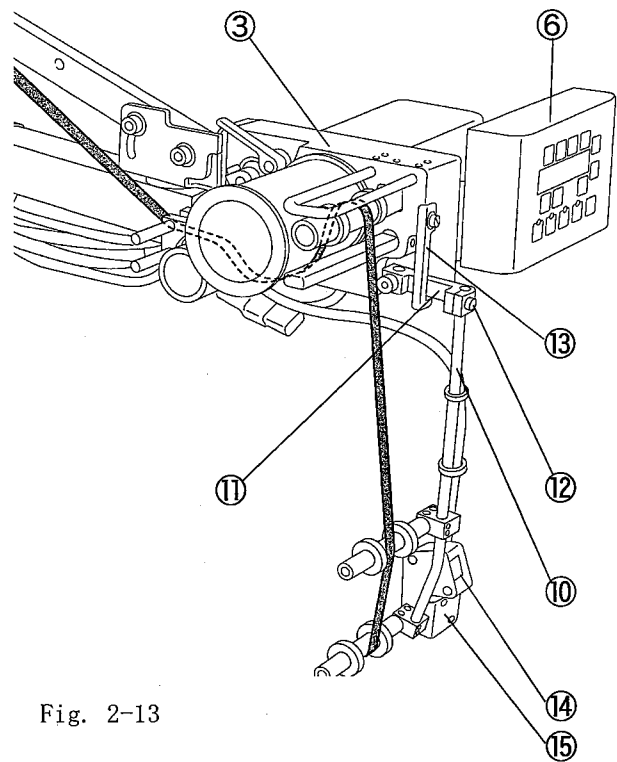

Fig. 2-13

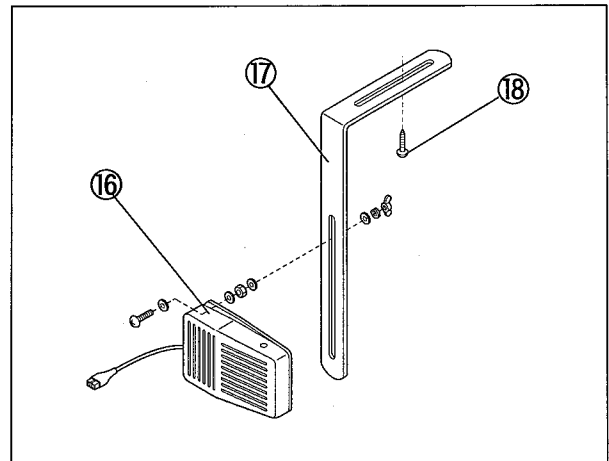

Fig. 2-15

## 2. Installation

### 2.4 Adjusting installation position

1. Loosen the bolts ② to adjust the right-and-left position of main pole ① and do not let the main pole obstruct sewing operation. (Fig. 2-16)

○ The main pole ① can be installed to a position that does not obstruct sewing operation by changing the position of clamp (rear) ③.

2. Adjust the position of tape feeder ④ to where the tape can be supplied to the presser foot smoothly and the tape feeder does not obstruct sewing operation.

○ For the right-and-left position and the height, adjust the sub pole by loosening the screws ⑤. (Fig. 2-17)

And the right-and-left position of tape feeder can be adjusted by loosening the screw ⑥. (Fig. 2-18)

○ For the back-and-forth direction, adjust the sub pole by loosening the screw ⑦. (Fig. 2-19)

○ Loosen the wing bolt ⑨ of tape feeder bracket ⑧, and adjust the tape feeder ④ to make tape feeding and sewing head toward the same direction. (Fig. 2-20)

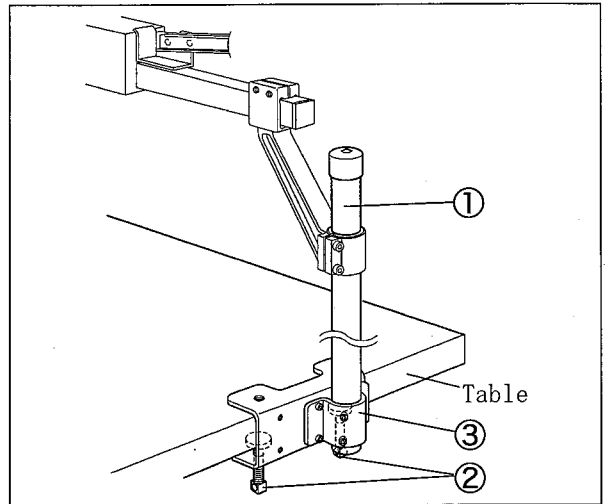

Fig. 2-16

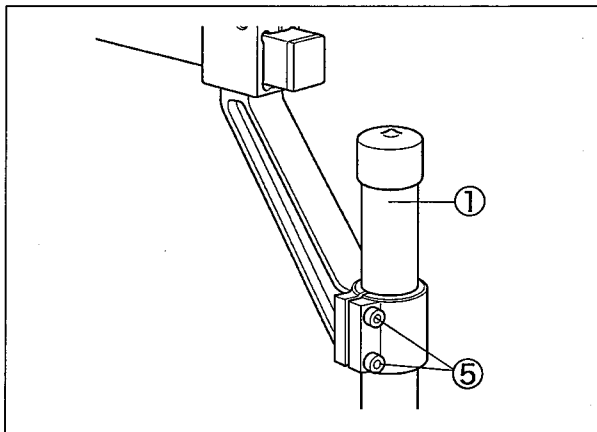

Fig. 2-17

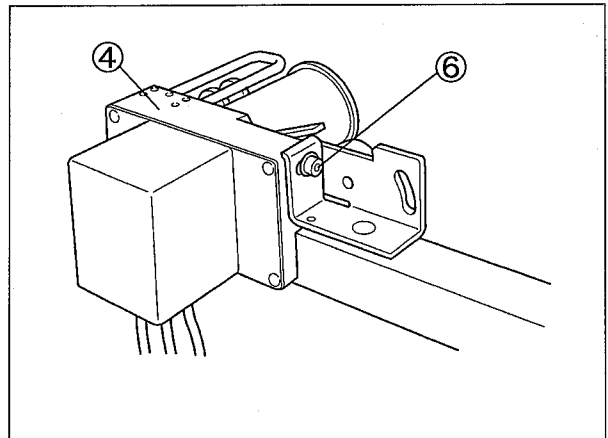

Fig. 2-18

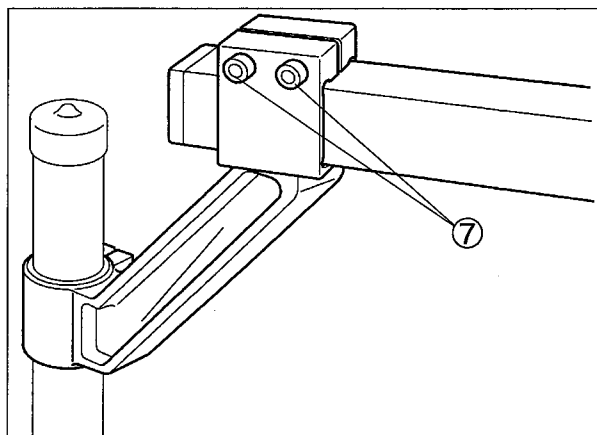

Fig. 2-19

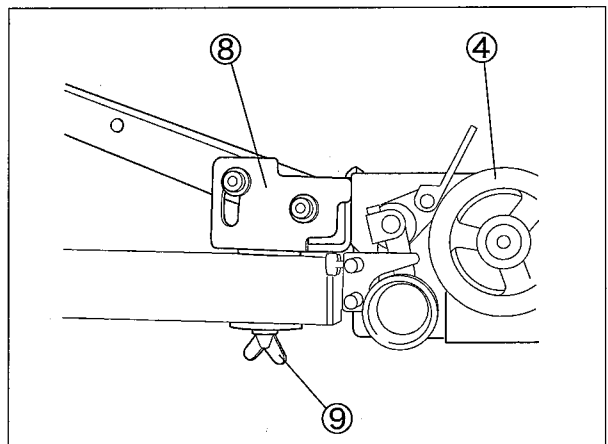

Fig. 2-20

3. Adjust the position of guide rollers⑨⑩ to where the tape can be supplied to the presser foot smoothly and do not let the guide rollers obstruct sewing operation. (Fig. 2-21)

For the back-and-forth position, loosen the screw⑪ to adjust the position of the guide stopper⑬ which for limiting the angle of guide roller arm⑫.

For the up-and-down position, loosen the screw⑭ to adjust the supporting bar⑮ up and down.

The up-and-down position for guide roller⑩ can also be adjusted by loosening the screws⑯.

4. To adjust the height of the distangle roller, loosen the screws⑰ and change the angle of the stay⑱.

5. The installation angle of the operating control box⑲ can be adjusted by the screws⑳. (Fig. 2-22)

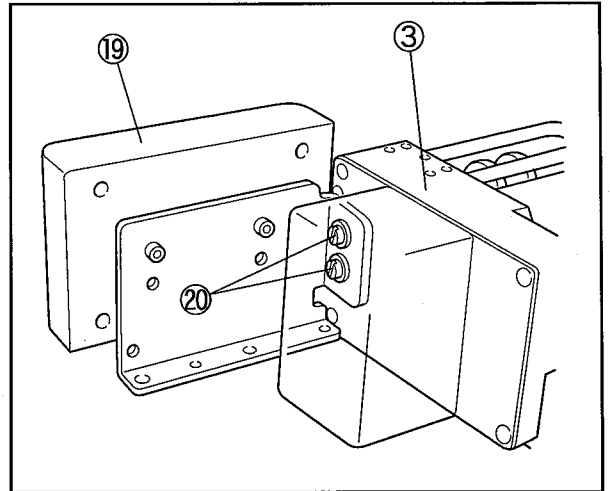

Fig. 2-22

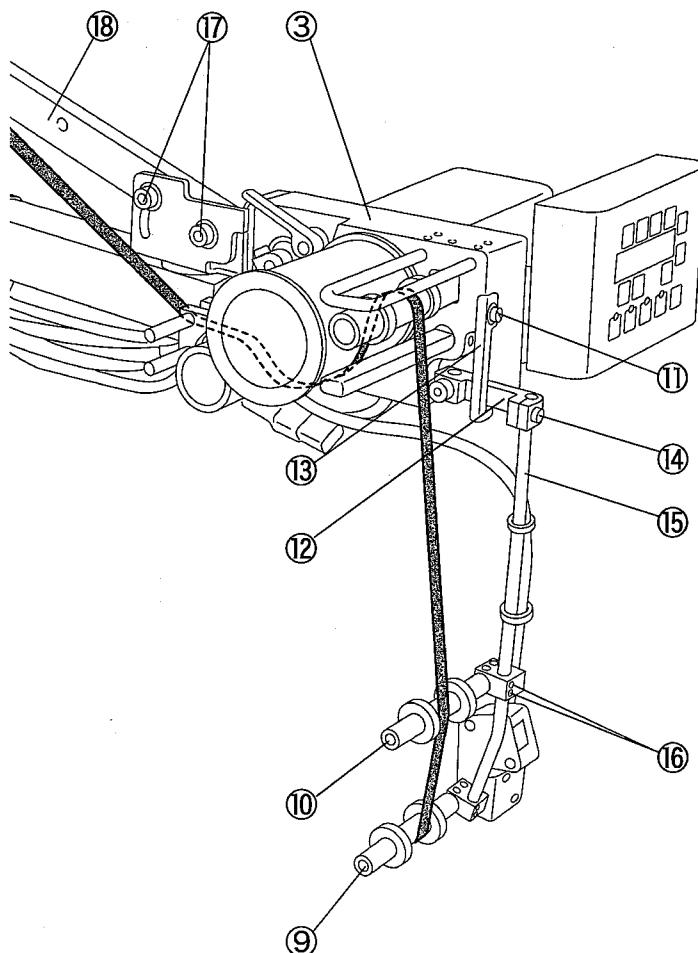

Fig. 2-21



## 2. Installation

### 2.5 Wiring

1. Connect the connectors on the control box ① with the connectors from the tape feeder ②, operating control box ③, knee switch ④ and process indicator ⑤. Make sure that they are the same in shape, color or mark.
2. Connect the intermediate cable ⑥ with the control box ①, tape feeder ② (two connectors) and distangle roller ⑦ (one connector).
3. Fix the cords by the wrapping bands ⑧ as shown in Fig. 2-24.
4. A plug that matches the outlet needs to be prepared separately. Connect the plug with the power cord ⑨. Then, insert it into the control box ①.
5. Make sure that the switch ⑩ on the control box ① has been turned off. Then, insert the plug into the outlet.

### WARNING

Use a single phase AC 100-240V power source.

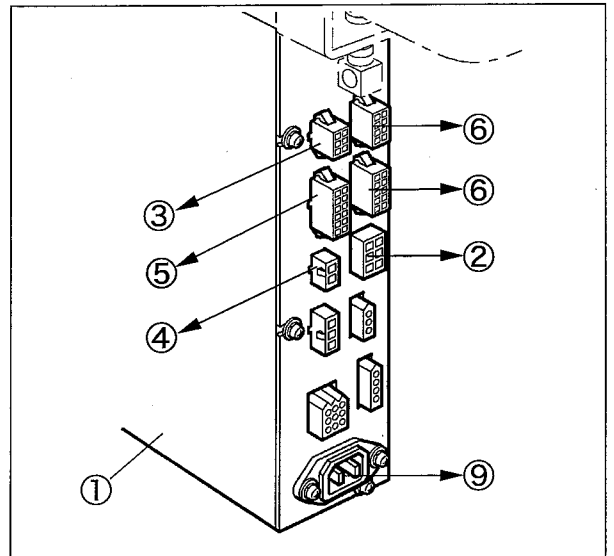

Fig. 2-23

### WARNING

Do not pull the cords strongly when banding them.

Fix the cords to a place away from rotating parts and moving parts.

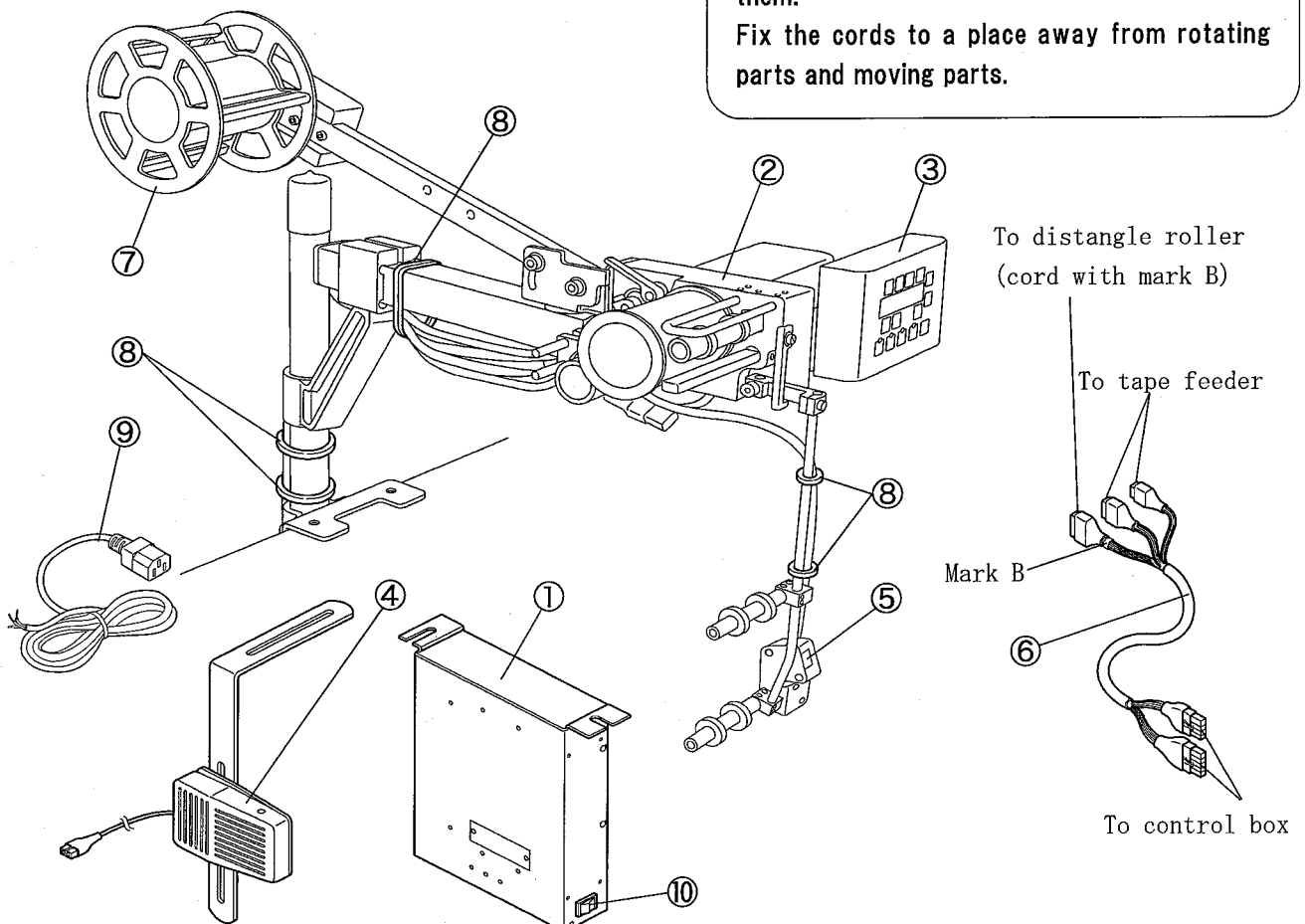

Fig. 2-24

Connecting to a 3-phase/380V power source

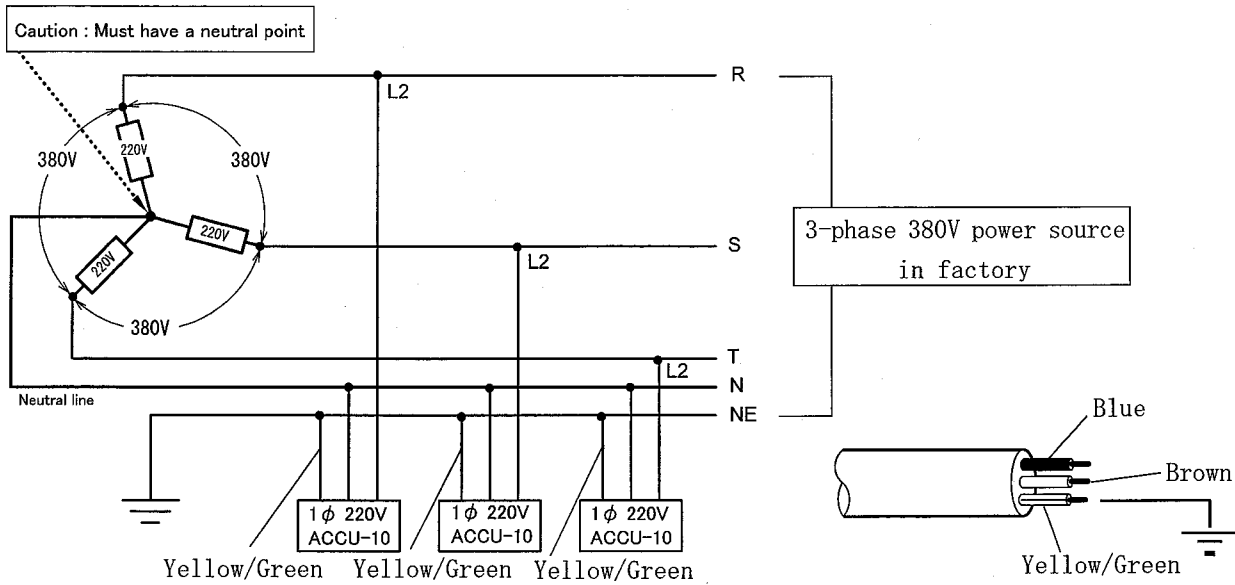

Fig. 2-25

Power cord of ACCU-10

**WARNING**

If the system has no neutral point, then the device is not suitable for this connection.

2.6 When tape can not be fed straightly

Pass a tape① between the sub roller② and main roller③. If the tape① slide to the right or the left because the sub roller② is not parallel to the main roller③, loosen the screws⑤ on the sub roller shaft arm④, and turn the screw⑥ of the sub roller②, so that the tape① can be fed straightly.

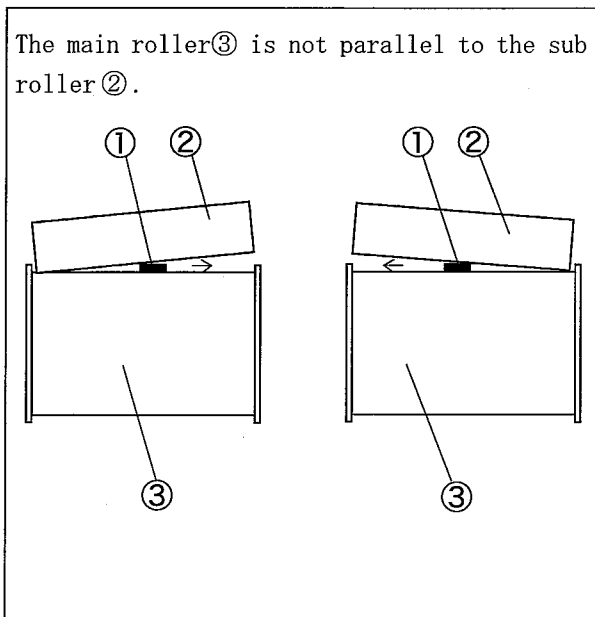

Fig. 2-26

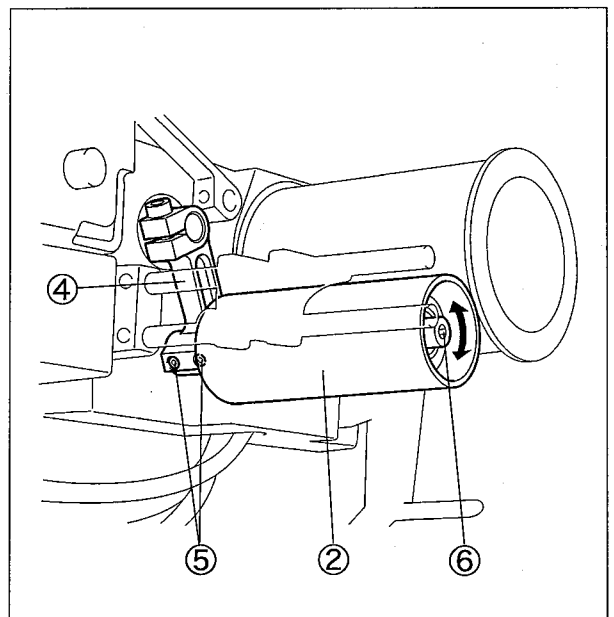

Fig. 2-27

## 2. Installation

### 2.7 Installation of other parts

The standard parts and extra parts (special order parts) may be different according to the type of sewing machines and the installation positions.

#### NOTE:

A rotation detector unit needs to be equipped when using the automatic process shifting function and the teaching mode.

#### 2.7.1 Parts for all types

ACCU-10-□□□-□1 (Standard)

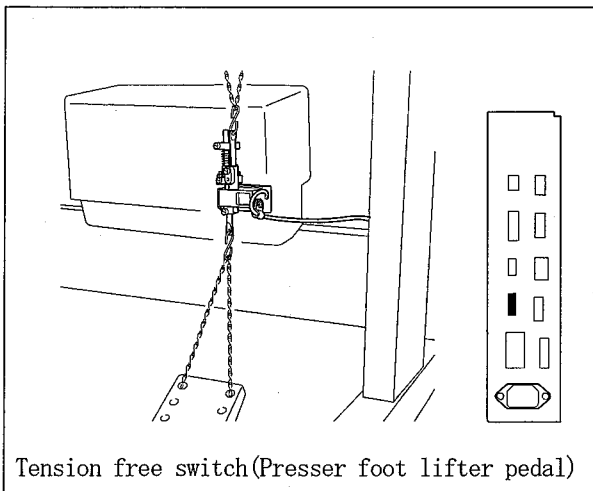

Fig. 2-28

ACCU-10-□□□-□2 (Standard)

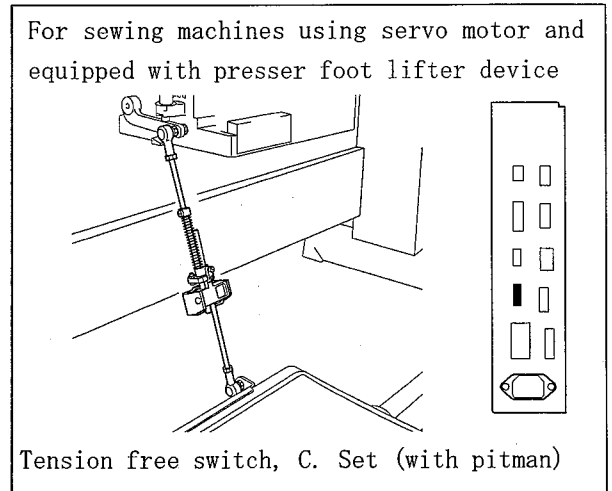

Fig. 2-29

ACCU-10 all types (Extra)

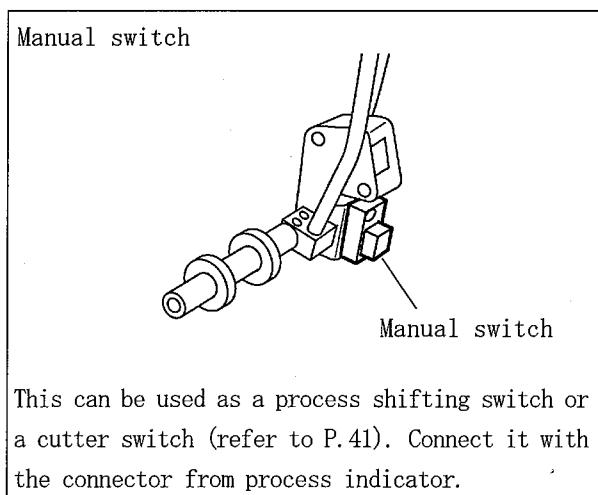

Fig. 2-30

ACCU-10 all types (Extra)

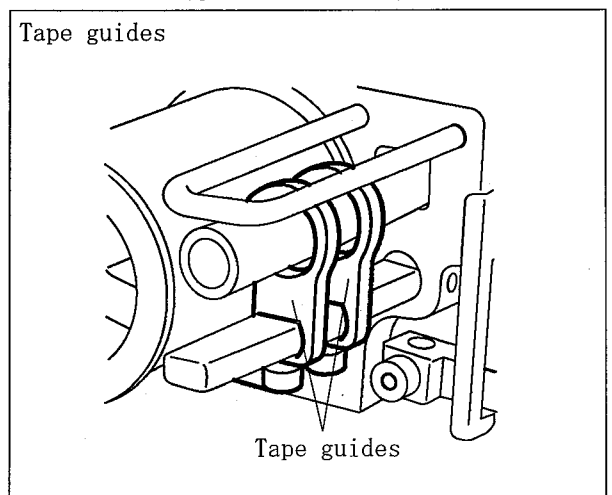

Fig. 2-31

ACCU-10-□□□-2□ (Standard)

Intermediate cable for motor

(Y motor, GY100 motor)

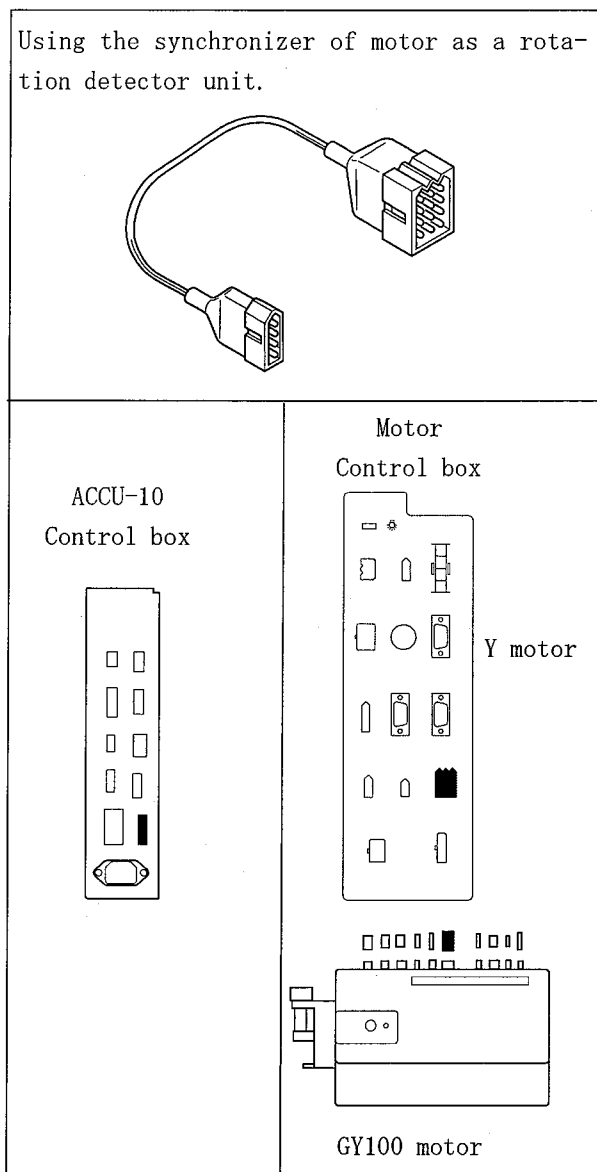

Fig. 2-32

### 2.7.2 ACCU-10-A □□ (For interlock)

ACCU-10-A □□ -3 □ (Standard)

ACCU-10-A □□ -1 □ (Standard)

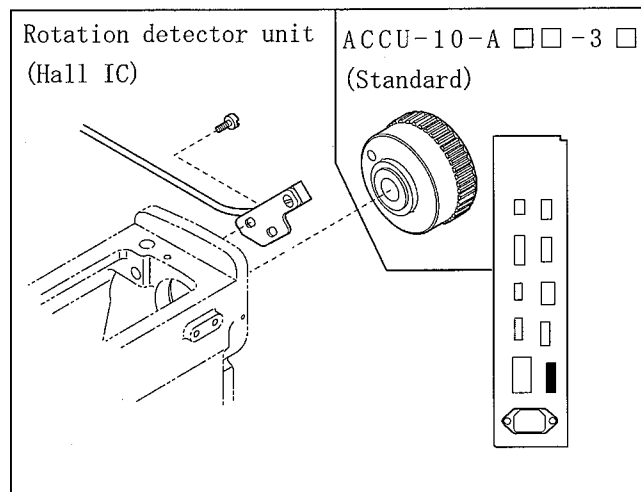

Fig. 2-33

ACCU-10-A □□ (Standard)

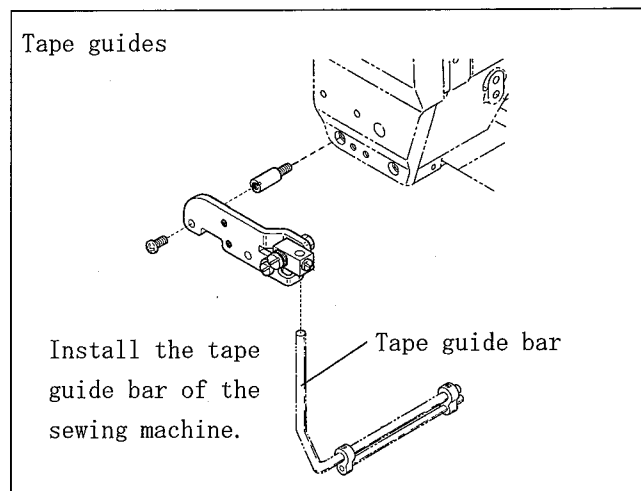

Fig. 2-34

ACCU-10-A □□ (Standard)

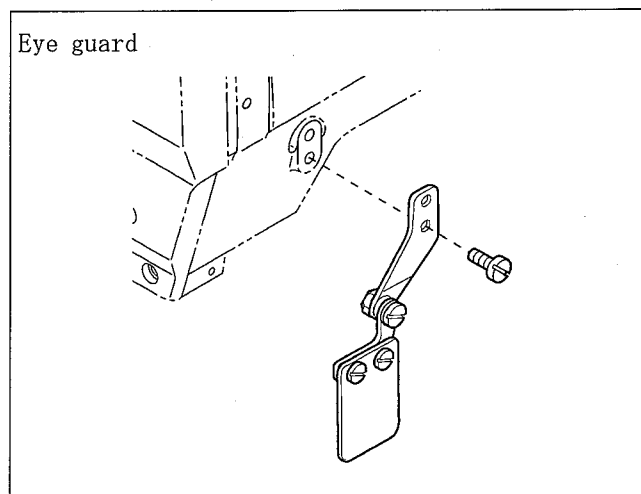

Fig. 2-35

## 2. Installation

ACCU-10-A □ □ (Extra)

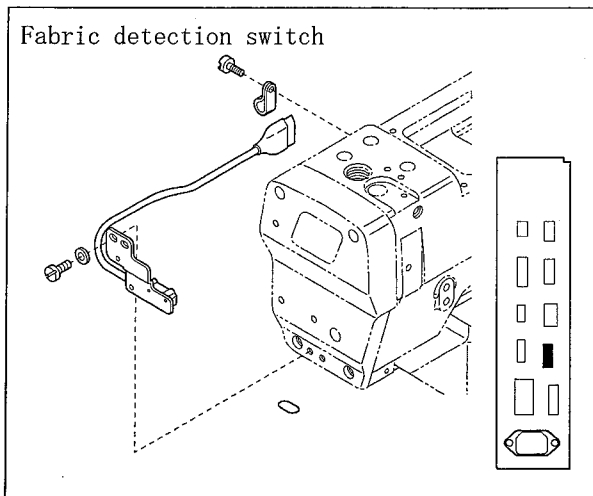

Fig. 2-36

### 2.7.3 ACCU-10-A1T (For interlock)

ACCU-10-A □ T (Extra)

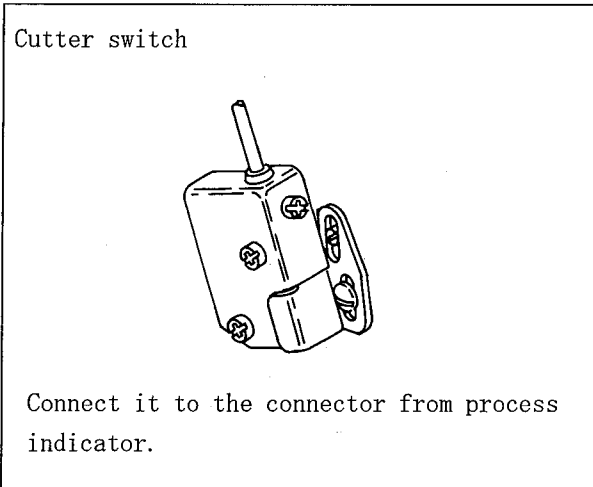

Fig. 2-37

### 2.7.4 ACCU-10-A1S (For interlock)

ACCU-10-A1S (Standard)

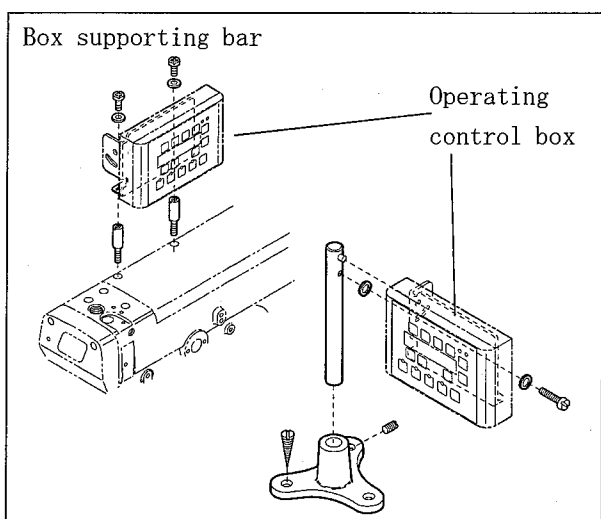

Fig. 2-38

ACCU-10-A □ S (Standard)

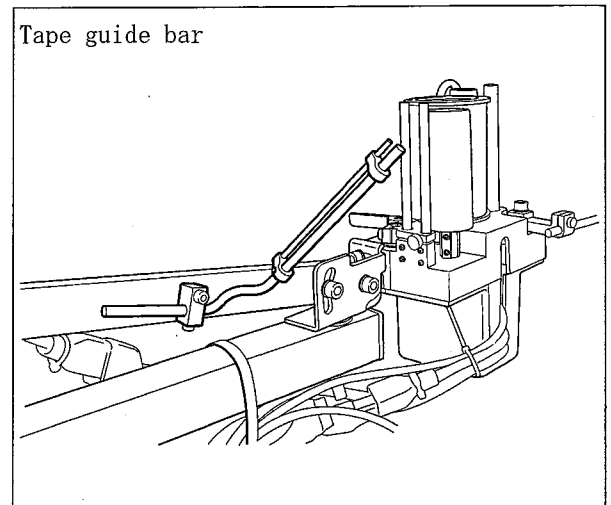

Fig. 2-39

ACCU-10-A □ S (Standard)

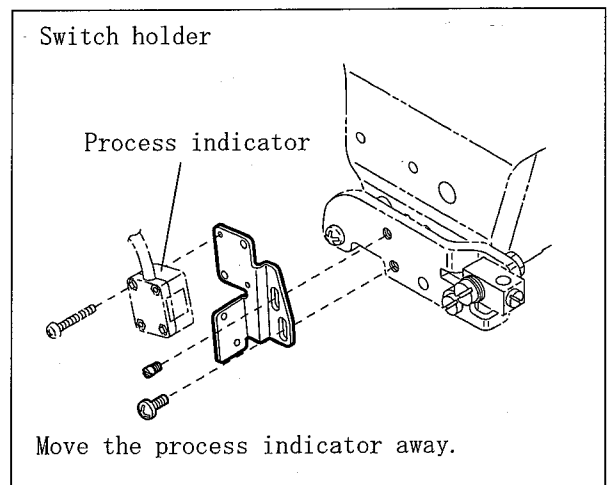

Fig. 2-40

ACCU-10-A1S (Extra)

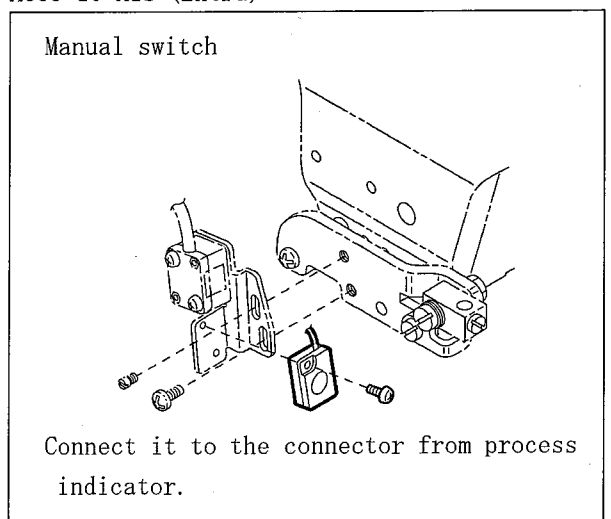

Fig. 2-41

2.7.5 ACCU-10-B1T (LG)

ACCU-10-B1T (Standard)

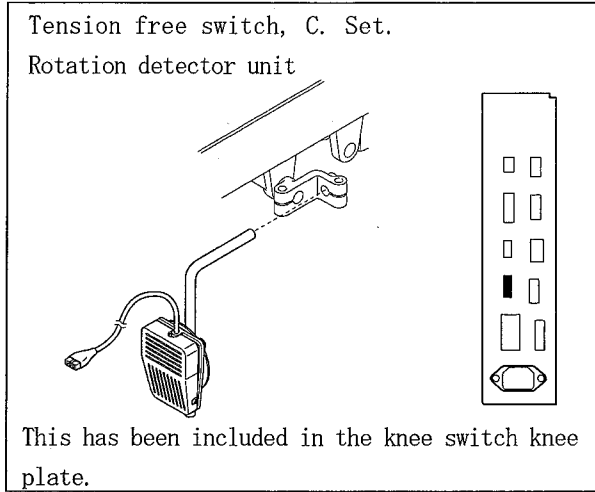

Fig. 2-42

ACCU-10-B1T (Extra)

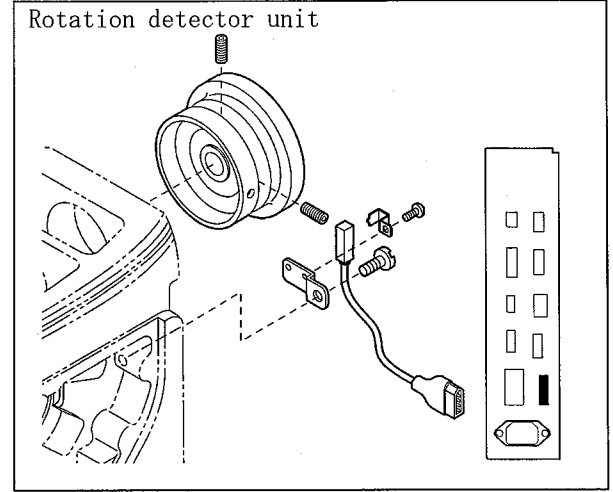

Fig. 2-43

2.7.6 ACCU-10-C1T (AZ8451)

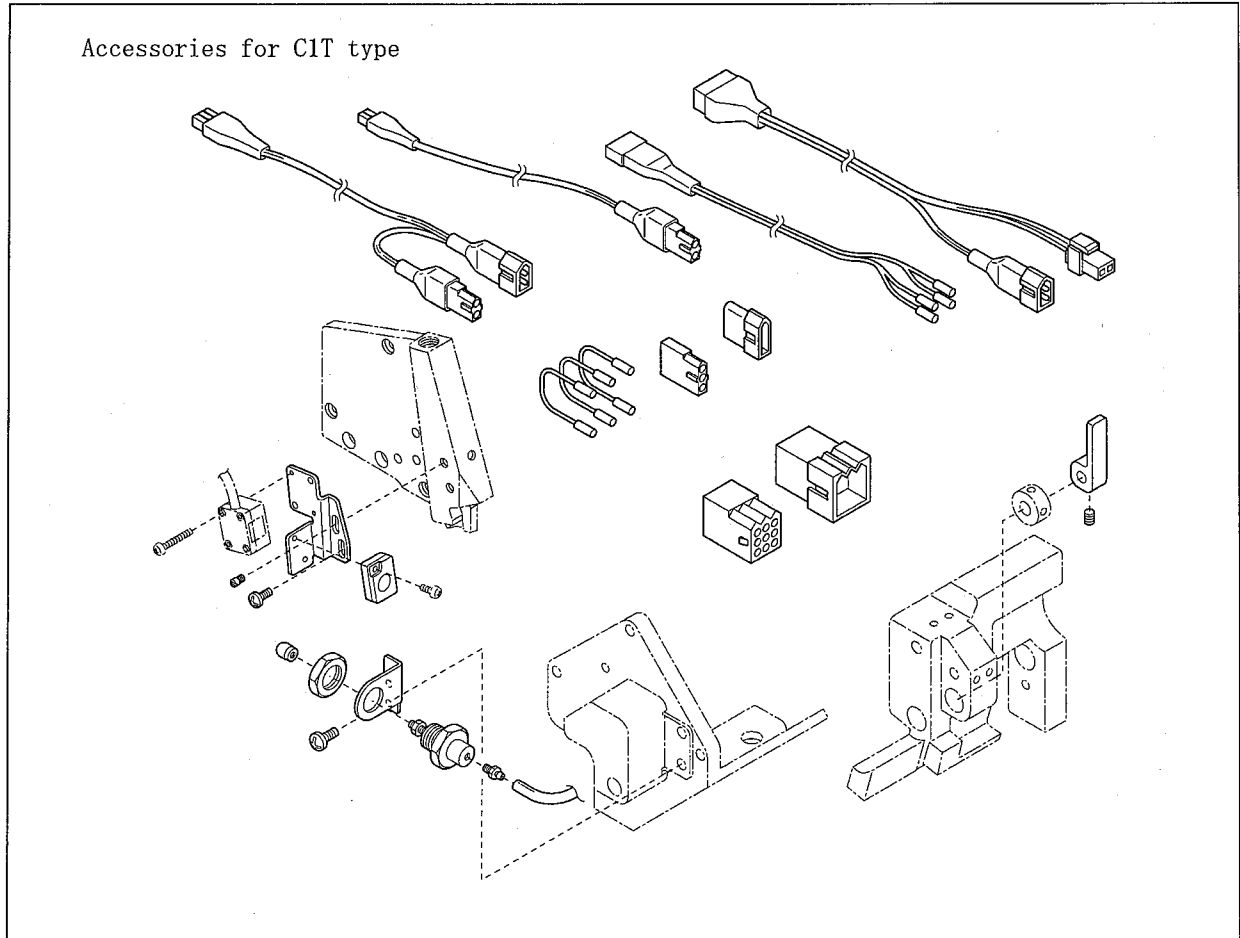

Fig. 2-44

# 3. Proper operation

## Term Explanation

**Mode** :A group of processes when sewing a part of material.

**Process** :Sewing operation under one sewing condition (tension and stitch count).

**Code** :Condition of process proceeding (manual, automatic, end).

## 3.1 Process shifting switch

The present process can be switched to the next by pressing process shifting switch.

The function of process shifting switch has been built into the knee switch as standard. The manual switch (extra parts) can also be used as a process shifting switch. For switching over, perform the steps in "Select switch cutter" of "4.11 Control functions".

### NOTE

When the manual switch is used as a process shifting switch, the knee switch can be used as a cutter switch.

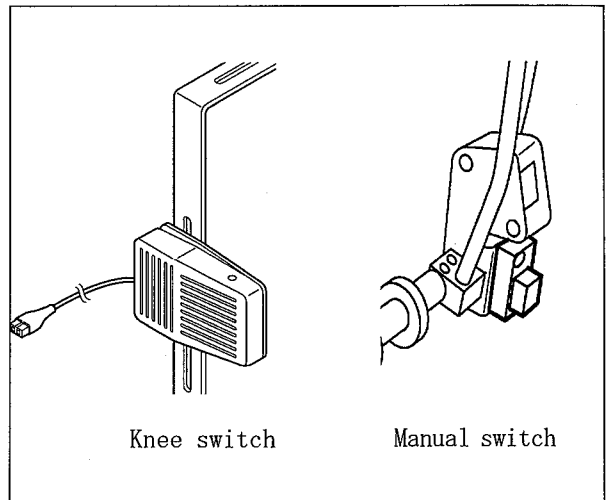

Fig. 3-1

## 3.2 Process Indicator

The process indicator usually displays process number. (Fig. 3-2)

When using the automatic tape feeding function, it will display "A". (Fig. 3-3)

When the clamp lever is pressed up, it will display "三". (Fig. 3-4)

When the presser foot is raised up, the process number will be blinking. (In case of using tension free switch, C. Set) (Fig. 3-5)

When a seam or a knot is detected, or there is an error, it will display "E". (Fig. 3-6)

When using the function of automatic process shifting (refer to "4.3.2 Setting code", code B or C), the timing of process proceeding can be monitored. (Fig. 3-7)

Lamp ① lights up when the process is going to proceed to the next automatically.

Lamp ② lights up when less than 100 stitches left before shifting to the next process.

Lamp ③ lights up when less than 60 stitches left before shifting to the next process.

Lamp ④ lights up when less than 30 stitches left before shifting to the next process.

Lamp ①-⑤ will be blinking together when less than 10 stitches left.

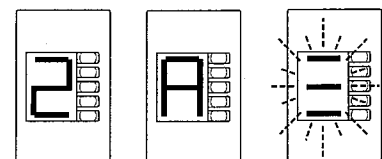

Fig. 3-2

Fig. 3-3

Fig. 3-4

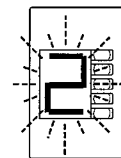

Fig. 3-5

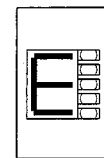

Fig. 3-6

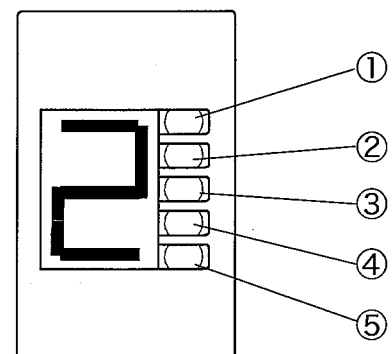

Fig. 3-7

### 3.3 Passing tape

- Pass a tape as shown in Fig. 3-8. Refer to the instruction manual for sewing machine to find out how to pass the tape from the guide roller① to the machine. (In case of ACCU-10-□□S, refer to Fig. 3-12.)
- Press the clamp lever② up, then the tape can be passed between the main roller③ and the sub roller④.
- Adjust the right and left position of the tape guides (bottom)⑤, (front)⑥ by hand. Adjust the tape guides (rear)⑦ by loosening the screws⑧. (Fig. 3-9, 3-10)
- Release the clamp lever after the tape has been passed.

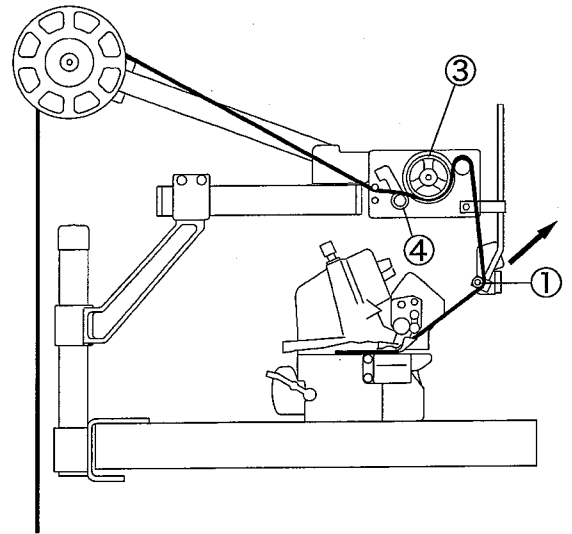

Fig. 3-8

NOTE:

- (1) When the clamp lever is pressed up, the mark in Fig. 3-11 will be shown on the process indicator.
- (2) Release the clamp lever only by spring tension. If press it strongly, the sub roller will be opened, and the tape can not be fed.

**ⓘ SUPPLEMENT**

Threading can be performed easily and adjustment can be made smoothly if pull the guide rollers up ( in case of the right side feeding, to operator side).

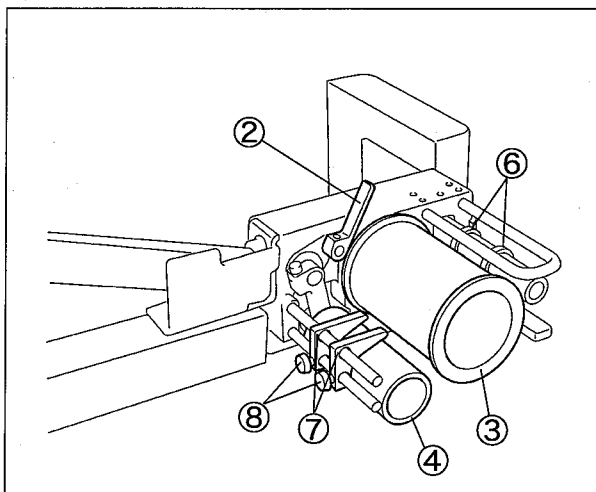

Fig. 3-9

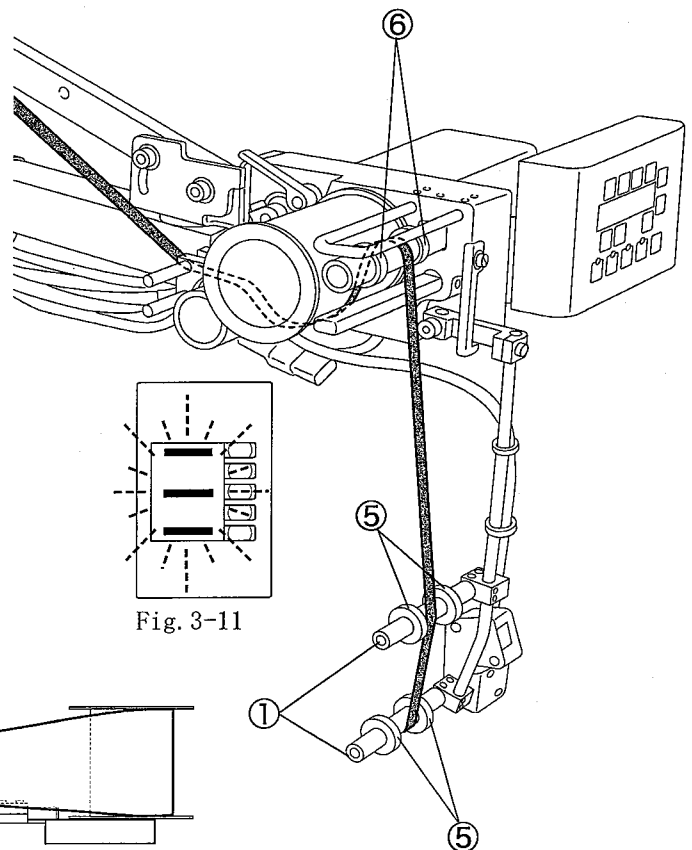

Fig. 3-11

Fig. 3-10

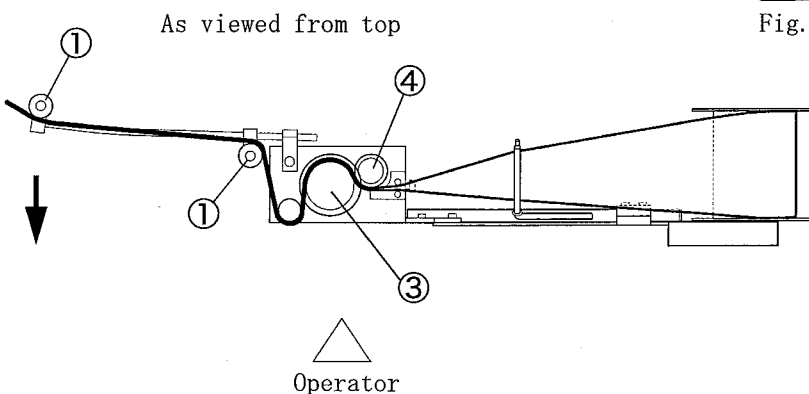

Fig. 3-12



### 3. Proper operation

#### ⚠ CAUTION

- In case of using the function of detecting seams and knots, set the machine up by referring to “4.8.5 Using function of detecting tape seams and knots”.
- When the type of tape is changed:
  1. Make sure the tape can be fed straightly. If not, adjust the tape by referring to “2.6 When tape can not be fed straightly”.
  2. The function of detecting tape seams and knots needs to be set up again. If not, seams and knots can not be detected correctly. For setting, refer to “4.8.5 Using function of detecting tape seams and knots”.

### 3.4 Tension free switch, c. set

When the presser foot is raised up, the tension free switch① starts to work. The tape will be without tension, and the process number on the process indicator will be blinking. (Fig. 3-11)

When the presser foot is lowered down, the tape will be with tension again.

#### NOTE

The tension for tape can also be adjusted, when the presser foot is raised up. For adjusting, refer to “4.9.7 Adjusting tension when the presser foot is up”.

ACCU-10-□□□-□1

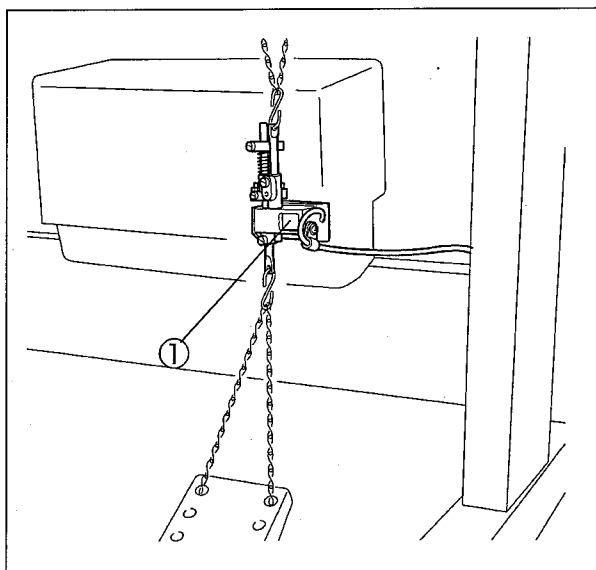

Fig. 3-13

ACCU-10-□□□-□2

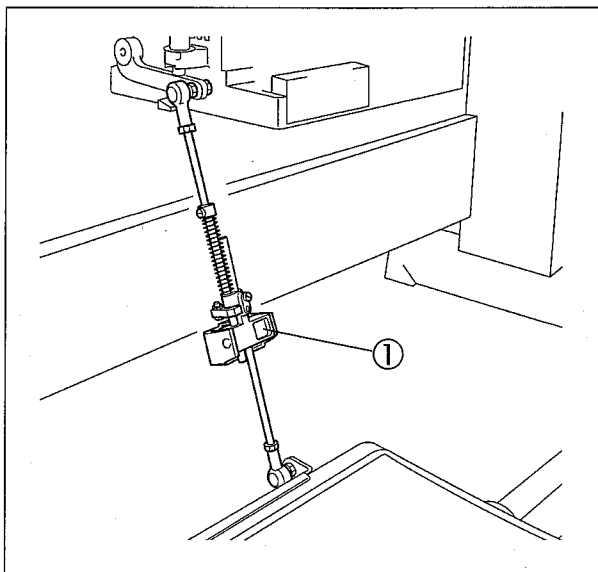

Fig. 3-14

ACCU-10-B1T-□3

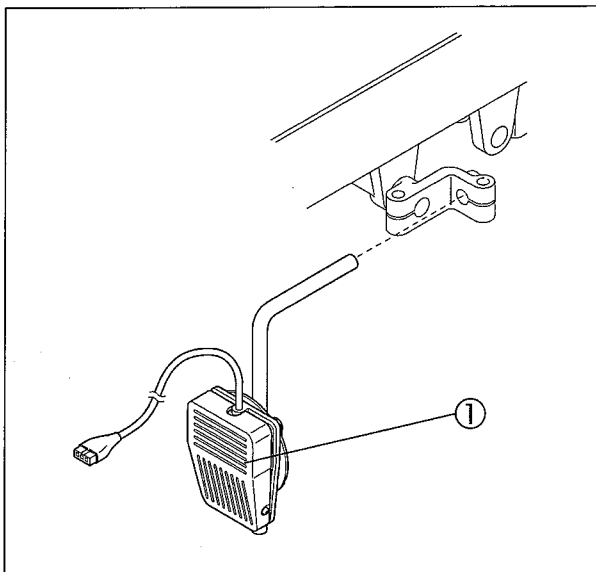

Fig. 3-15

### 3.5 Cutter switch (Extra parts)

The cutter starts working when pressing the cutter switch down. The function of cutter switch is usually built into the manual switch. The knee switch can also be used as a cutter switch. For switching over, perform the steps in "Select switch cutter" of "4.11 Control functions".

#### NOTE

- When the knee switch is used as a cutter switch, the manual switch can be used as a process shifting switch.
- ACCU-10 can only control air-operated cutter device.

A cord to connect the solenoid (for cutter) with the control box needs to be prepared separately.

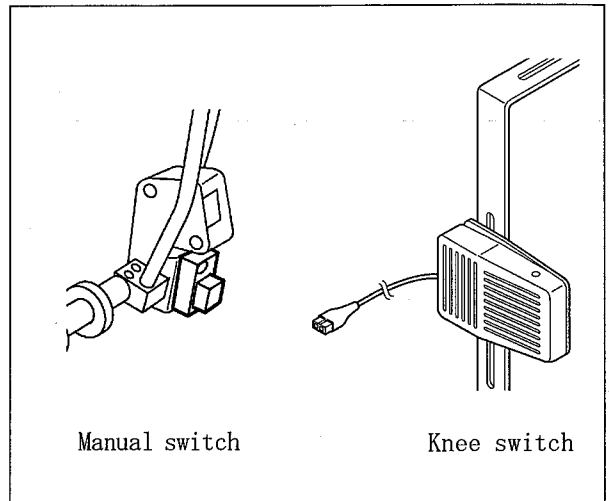

Fig. 3-16

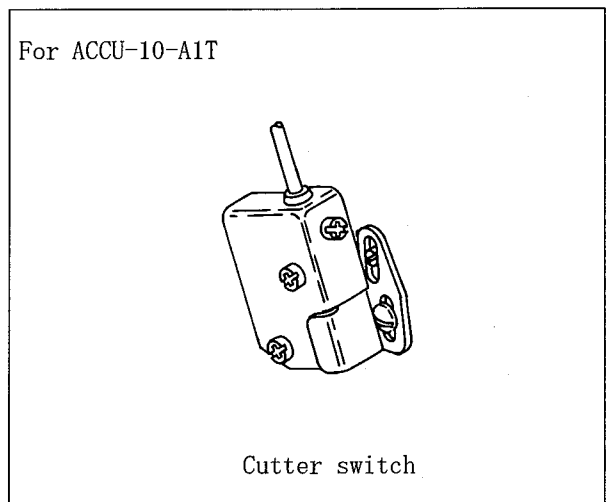

Fig. 3-17

# 4. Operating control panel

## Term Explanation

**Mode** :A group of processes when sewing a part of material.

**Process** :Sewing operation under one sewing condition (tension and stitch count).

**Code** :Condition of process proceeding (manual, automatic, end).

## 4.1 Name of each part

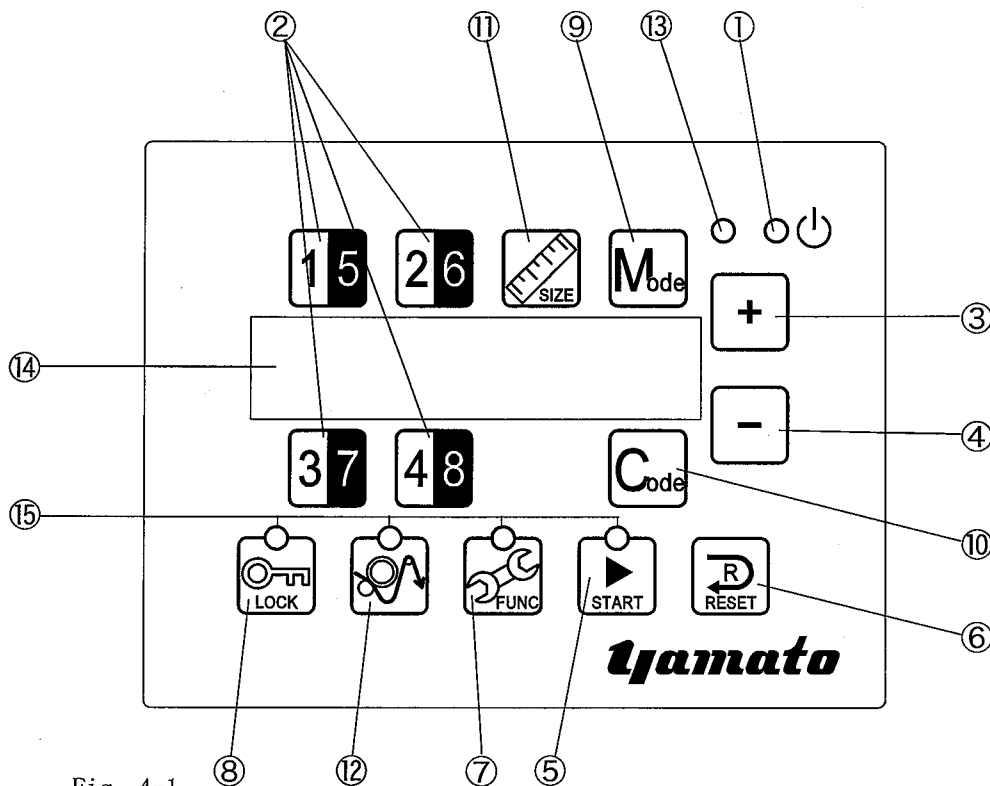

Fig. 4-1

- |                                 |   |
|---------------------------------|---|
| ① Power lamp                    | This lamp lights up when power supply ON.   |
| ② Process switch                | This is used to select process (1-8).   |
| ③ + switch                      | This is used to increase a setting value.   |
| ④ - switch                      | This is used to decrease a setting value.   |
| ⑤ Start switch                  | As long as the lamp(LED) on the start switch is on, the sewing operation is possible.   |
| ⑥ Reset switch                  | This is used to return to the first process.  |
| ⑦ Function switch               | This is used to change the settings related to functions.   |
| ⑧ Lock switch                   | This is used to disable switches in order to prevent mis-operation during operation.  |
| ⑨ Mode switch                   | This is used to shift mode (50 modes).  |
| ⑩ Code switch                   | This is used to shift codes (3 codes).  |
| ⑪ Size setting switch           | This is used to set the size when using automatic processes proceeding function.  |
| ⑫ Automatic tape feeding switch | This is used to feed the tape without controlling tension.  |
| ⑬ Fabric detector lamp          | This lamp lights up when there is no material. (In case of fabric detection, fabric detection switch, c. set needs to be equipped.) |
| ⑭ LCD                           | Setting values etc. will be shown on this display.  |
| ⑮ LED                           | This lamp lights up when the switch is turned on.   |

## 4.2 Display Processes

○ 8 processes or less can be set in one mode. LCD can only display 4 processes at one time. Only the available processes will be displayed.

○ Press the switch ① to select a process. (Fig. 4-7)  
The tension value of the selected process will be blinking and marked with [>][<]. At the same time, the setting value of size and code will be displayed. (Fig. 4-5)

In case of code A, the value of size will not be displayed.

○ Hold down the switch ① for three seconds or more to select and display processes 5 - 8, during processes 1 - 4 are displayed. The tension value of the selected process will be marked with [▶][◀]. (Fig. 4-3)

Hold down the switch ① for three seconds or more to select and display processes 1 - 4, during processes 5 - 8 are displayed.

○ The process indicator displays corresponding process number.

### 4.2.1 Setting tension

1. Press the switch ① to select a process, the value of tension blinks.

2. Change the tension value by pressing the switches ② and ③.

Setting value "999" is the weakest, and "001" is the strongest tension.

When changing the tension values of other processes, repeat the steps mentioned above.

3. Press the start switch ④ (LED ⑤ On) to start sewing.

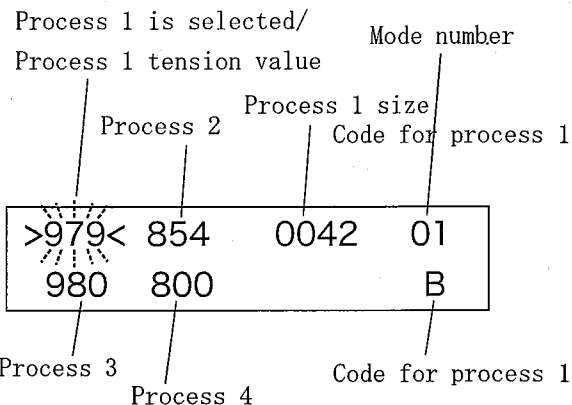

Fig. 4-5 Processes 1-4 are displayed.

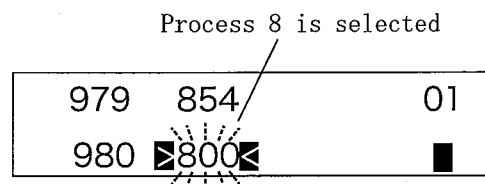

Fig. 4-6 Processes 5-8 are displayed

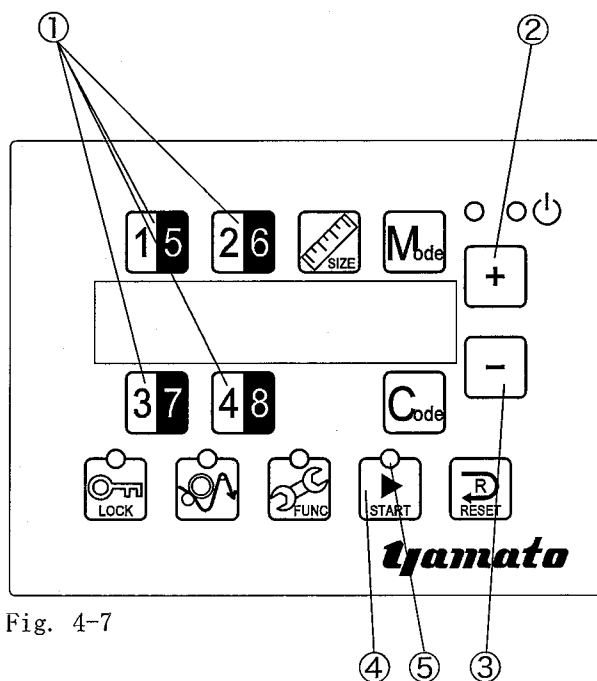

Fig. 4-7

## 4. Operating control panel

### 4.2.2 Setting code

There are 3 ways to switch the present process to the next process during sewing operation: manual (Code A), automatic (Code B, C).

#### Setting method

1. **15/26/37/48** Select a process.

2. **C<sub>code</sub>** Code blinks.

3. **+/-** Change the code.

4. **START** (LED On) Finished.

○ Set the code to [A], the processes will be switched by pressing process shifting switch (knee switch or manual switch). In case of using manual switch, refer to "4.10 Control functions".

○ Set the code to [B], the stitch count will be measured at the point that the process is changed. After sewing preset stitch count, the present process will proceed to the next process automatically. In case that code [B] is used in process 1, the start point of sewing may not be very stable. (A rotation detector unit needs to be equipped.)

○ Set the code to [C], ACCU-10 will work with the fabric detection switch together. The stitch count will be measured when the sewing machine starts to sew the material. After sewing the preset stitch count, the present process will proceed to the next process automatically. (Rotation detector unit or Hall IC, and fabric detection switch need to be equipped.)

○ Set the code to [■], the following processes (including the present one) will be invalid.

For example, set the code of process 3 to ■, processes 1 and 2 are effective, but the processes 3-8 will be ineffective. (Fig. 4-11)

In this case, the processes 3-8 will not be displayed during sewing procedure. (Fig. 4-12)

When want to select process 4, change the code of process 3 to "A", "B" or "C".

When the process proceed to 8, then it will go back to process 1 automatically. It is not necessary to set the code to "■".

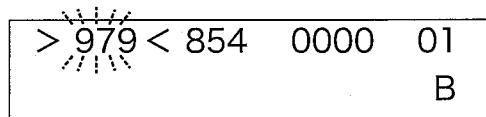

Fig. 4-8

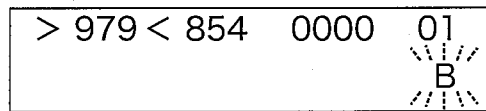

Fig. 4-9

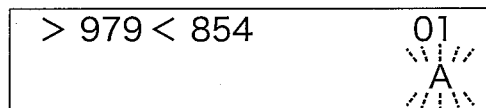

Fig. 4-10

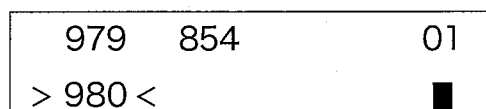

Fig. 4-11 Setting code

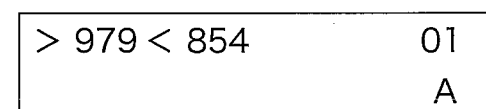



Fig. 4-12 During sewing procedure

### 4.2.3 Setting size

To set how many stitches the sewing machine sews before proceeding to the next process (Code B, C).

1.  Select a process.

2.  Change the code to "B" or "C".

(Refer to "4.2.2 setting code")

3. 

4.  Change the value of size.

5.  (LED On) Finished.

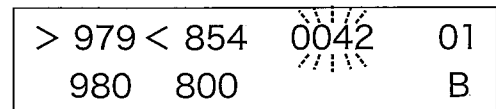



Fig. 4-13

### 4.3 Changing mode

1. 

2.  Select a new mode number.

(The number can be selected from 1 to 50.)

3.  (LED On) Finished.

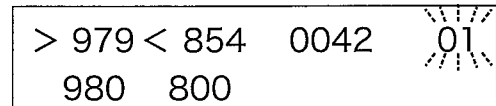

Fig. 4-14

## 4.4 Setting examples

### Example 1: Mode 1, One Process

Process	Tension	Code
1	985	A

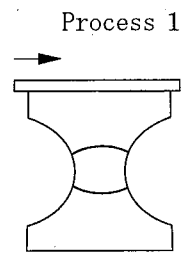

Fig. 4-15

1. Mode
2. Set the mode number to "1".
3. Select process 1.
4. Set the tension value to "985".
5. Code
6. Set the code to "A".
7. Select process 2.
8. Code
9. Set the code to "■".
10. Finished.

>999< 959 0000 01  
B

>985< 959 0000 01  
B

>985< 959 01  
A

985 >959< 01  
■

>985< 01  
A

Example 2: Mode 2, Two Processes

Process	Tension	Code
1	985	A
2	880	A

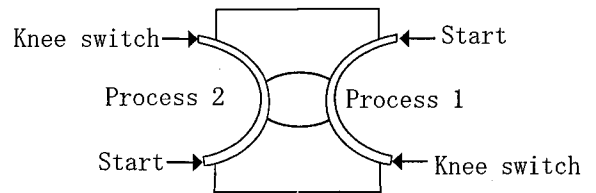
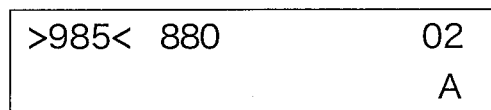
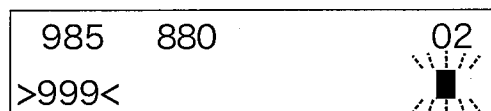
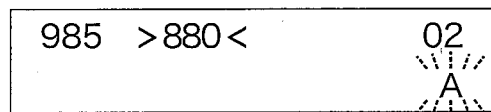
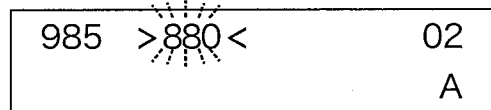
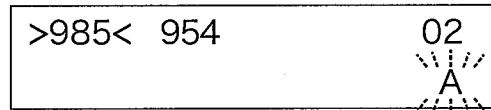
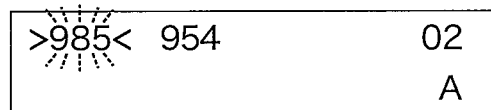
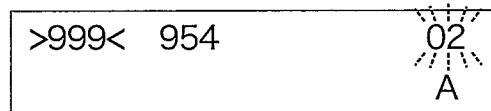

Fig. 4-16

1. Mode
2. Set the mode number to "02".
3. Select process 1.
4. Set the tension value to "985".
5. Code
6. Set the code to "A".
7. Select process 2.
8. Set the tension value to "880".
9. Code
10. Set the code to "A".
11. Select process 3.
12. Code
13. Set the code to "■".
14. Finished.



During sewing operation

- Press the manual switch or the knee switch at the end of the process 1 to shift to the next process.
- Press the manual switch or the knee switch again at the end of the sewing operation.

**ⓘ SUPPLEMENT**

If the fabric detection switch is equipped, perform the steps in "4.9 Controlling devices on sewing machine" to turn on "FINISH" ("4.9.1 List of cutter device functions"). The process 1 can be shift to the process 2 without pressing the process shifting switch.



## 4. Operating control panel

### Example 3: Mode 3, Three Processes, Automatic process proceeding (from process 2 to process 3)

Process	Tension	Code	Size
1	985	A	—
2	880	B	85
3	980	A	—

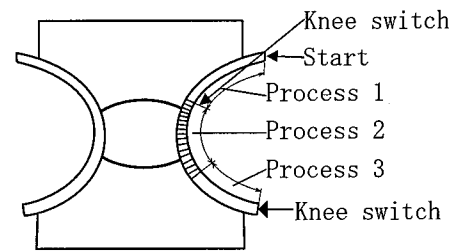
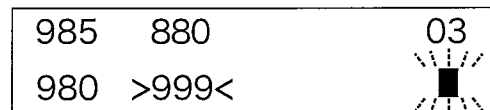
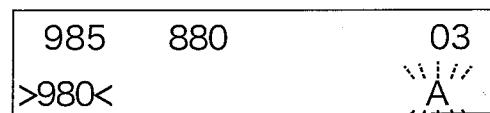
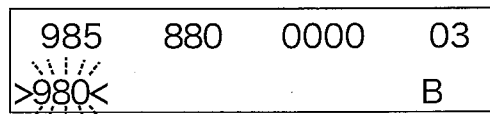
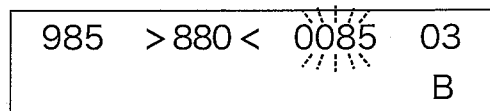
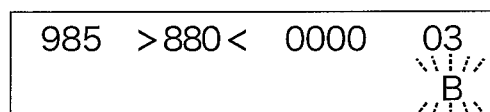
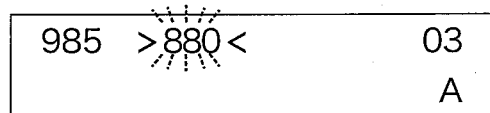
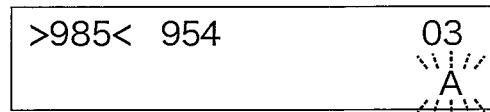
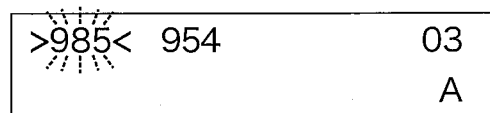
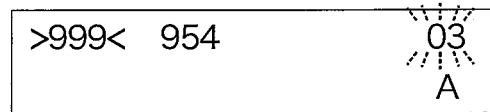

Fig. 4-17

The rotation detector unit needs to be equipped.

1. **M<sub>ode</sub>**
2. **+ / -** Set the mode number to "03".
3. **15** Select process 1.
4. **+ / -** Set the tension value to "985".
5. **C<sub>ode</sub>**
6. **+ / -** Set the code to "A".
7. **26** Select process 2.
8. **+ / -** Set the tension value to "880".
9. **C<sub>ode</sub>**
10. **+ / -** Set the code to "B".
11. **SIZE**
12. **+ / -** Set the size to "0085".
13. **37** Select process 3.
14. **+ / -** Set the tension value to "980".
15. **C<sub>ode</sub>**
16. **+ / -** Set the code to "A".
17. **48** Select process 4.
18. **C<sub>ode</sub>** Set the code to "■".
19. **START** Finished.



#### During sewing operation

- Press the manual switch or the knee switch at the end of process 1 to shift to the process 2.
- The process will proceed to the process 3 automatically at the end of process 2.
- Press the manual switch or the knee switch at the end of sewing.

**Example 4 Mode 4 Automatic process proceeding (from process 1 to 2, process 2 to 3)**

Process	Tension	Code	Size
1	985	C	120
2	880	B	85
3	980	A	—

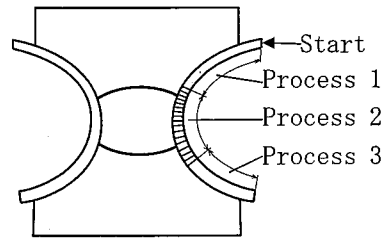
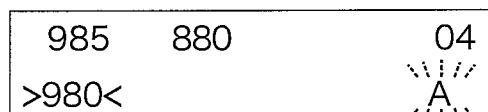
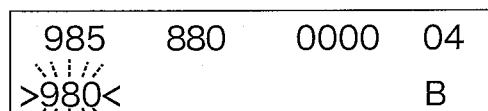
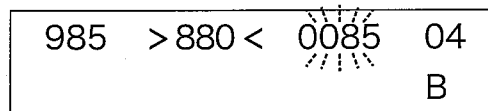
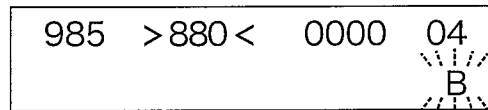
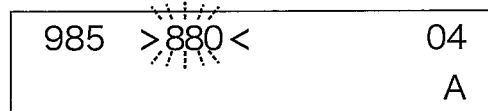
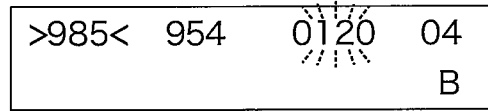
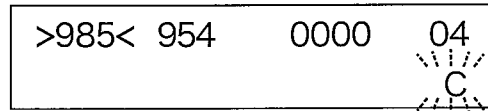
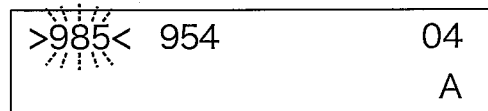
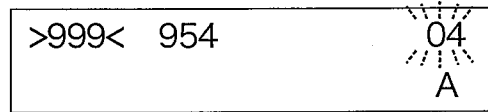

Fig. 4-18

The rotation detector unit and fabric detection switch need to be equipped.

1. Set the mode number to "04".
2. Set the mode number to "04".
3. Select process 1.
4. Set the tension value to "985".
5. Set the code to "C".
6. Set the code to "C".
7. Set the size to "0120".
8. Set the size to "0120".
9. Select process 2.
10. Set the tension value to "880".
11. Set the code to "B".
12. Set the code to "B".
13. Set the size to "0085".
14. Set the size to "0085".
15. Select process 3.
16. Set the tension value to "980".
17. Set the code to "A".
18. Set the code to "A".



## 4. Operating control panel

19.  Select process 4.

20.  Set the code to "■".



21.  Finished.



985	880	04
980 >999<		

>985<	880	0120	04
980			C



Perform the following steps to turn on "FINISH".

1.  Press this switch 3 times.

2.  /  Select "FINISH".

3.  /  Select "ON".

4.  /  Select "FINISH CUT".

5.  /  Set the desired setting value.

6.  Finished.

FRONT	
F3 00	OFF

FINISH	
F3 01	OFF

FINISH CUT	
F3 06	30

FINISH	
F3 01	ON

### During sewing operation

○The process 1 shifts to process 2, the process 2 shifts to process 3 automatically.

○At the end of process 3, the fabric detection switch detects the end of material, and shifts back to process 1 automatically.

## 4.5 Key lock



To activate the locking mechanism:

Press  (LED On) .

To release the locking mechanism:

Hold down  for more than 3 seconds.

During lock switch on:

All switches except for   will be disabled.

## 4.6 Reset switch

If you made a mistake during sewing operation:

Press  to go back to process 1 and continue sewing.

## 4. Operating control panel

### 4.7 Automatic tape feeding

To feed a tape without controlling tension:





Press  (LED On) and start sewing.

To feed a tape with controlling tension:

Press  (LED Off) and start sewing.

#### 4.7.1 Setting detection level

This is used when the tape is too heavy or too light than the previous one. The start timing of tape feeding can be adjusted by performing the following steps.

1.  (LED On)
2.  The setting value of detection level blinks.
3.  Change the setting value.
4.  Finished.





When the tape is heavier than the previous one, increase the setting value.

When the tape is lighter than the previous one, decrease the setting value.

Set the setting value as low as possible and make sure the tape will not be fed by its gravity force.

#### 4.7.2 Setting feeding amount

This is used to adjust the feeding amount of tape.

1.  (LED On)
2.  The setting value of time (feeding amount) blinks.
3.  Set a proper feeding amount.
4.  Finished.

To increase the feeding amount, set a bigger setting value.

To decrease the feeding amount, set a smaller setting value.

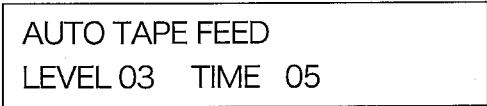

AUTO TAPE FEED  
LEVEL 03 TIME 05

Fig. 4-19



AUTO TAPE FEED  
LEVEL 07 TIME 05

Fig. 4-20



AUTO TAPE FEED  
LEVEL 07 TIME 05



Fig. 4-21



## 4.8 Convenient functions

### 4.8.1 Learning function (Teaching mode)

When the learning function is used, the stitch count of the material is measured by the device. The device will memorize the stitch count and the tension value which has been set manually. The following sewing operation will be carried out by using the memorized setting. 8 processes are available in this teaching mode.

#### Setting method

1.  Mode
2.  Select a new mode number.  
(Refer to "4.3 Changing mode".)

3.  FUNC
4.  Code Start teaching.

5. Set a proper tension value according to the material and tape. The device starts counting stitches. The default has been input in each process (total 8 processes). And the code has been set to "B". Stop sewing at the point that tension needs to be changed, and shift to the next process by pressing the process shifting switch (the manual switch or the knee switch).

6. After setting the last process, press the process shifting switch (the manual switch or the knee switch) twice during the sewing machine is stopped to finish teaching. Then the setting will be saved.

7. For fine adjustment of the stitch count, tension and code changing, refer to each setting method.

TEACHING MODE			
F1 00			

Fig. 4-22

> 940 <	948	0000	01
900	850	TEACH	B

Fig. 4-23

#### NOTE

When using the learning function, a rotation detector unit or a HALL IC needs to be equipped.

**4.8.2 Mode copy function**

When sewing similar material, it is easier to program by using mode copy function.

After making the copy, be sure to change the sewing conditions (tension, stitch count) according to the material.

Before making copy, shift to the mode that needs to be copied.

**Example Make a copy of mode 2 to build up mode 4.**

1.  Mode

2.  Select mode "02".

3.  FUNC

4.  Select "MODE COPY"

5.  Select a new mode number "04".

6.  Code Copy finished.

7.  START Finished.

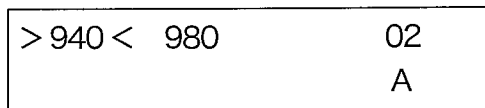

Fig. 4-24

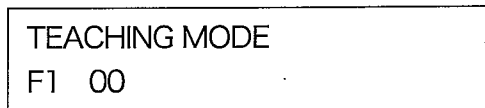

Fig. 4-25

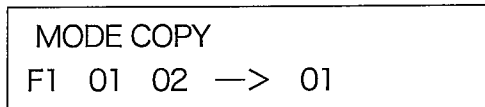

Fig. 4-26

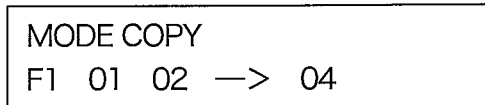

Fig. 4-27

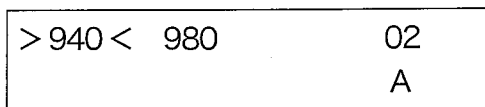

Fig. 4-28

### 4.8.3 Combining modes

Sewing can be carried out from one mode to another by using two different mode alternately, or using different modes sequentially.

For example, such a combination of modes is useful for right and left leg opening (sewing is carried out while two modes are being used alternately) or right and left around leg opening and around waist (three modes are used in sequence).

This function also can be used in case that the sewing operation needs more than 8 processes.

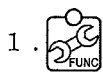

2.  Select "NEXT MODE NO".

3.  Select the mode number that needs to be combined.

4.  Finished.

(In case of continue combining, press .)

TEACHING MODE  
F1 00

Fig. 4-29

NEXT MODE NO  
F1 02 02 → ■■

Fig. 4-30

NEXT MODE NO  
F1 02 02 → 04

Fig. 4-31

### NOTE

The process will not go back to the first mode automatically. Combine the last mode to the first one to make a cycle.



## 4. Operating control panel

### Example of Combining modes:

Make a cycle of mode 3 → mode 4 → mode 1 (in case the setting values have been input in each mode).

Mode 3				Mode 4				Mode 1		
Process	Tension	Code	Size	Process	Tension	Code	Size	Process	Tesion	Code
1	985	A		1	980	A		1	985	A
2	880	B	85	2	880	B	88			
3	980	A		3	985	A				

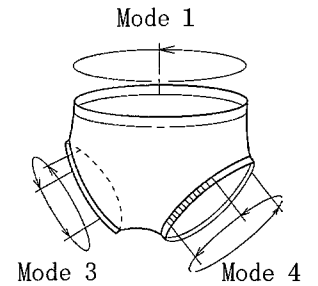

Fig. 4-32

1. Mode
2. Select the beginning mode number "03".
3. FUNC
4. Select "NEXT MODE NO".
5. Select the next mode number "04".
6. Code
7. Select the next mode number "01".
8. Code
9. Select the beginning mode number "03".
10. START Finished.

> 985 <	880	03
980		A

NEXT MODE NO
F1 02 03 → ■■

NEXT MODE NO
F1 02 03 → 04

NEXT MODE NO
F1 02 04 → ■■

NEXT MODE NO
F1 02 04 → 01

NEXT MODE NO
F1 02 01 → ■■

NEXT MODE NO
F1 02 01 → 03

### 4.8.4 Setting distangle roller

○Setting the rotation speed of distangle roller (Default: 05)

Item name : MOTOR SPEED F2 00

◆To make the speed faster, increase the setting value.

◆To make the speed slower, decrease the setting value.

○Setting the rotation direction of distangle roller

Item name : SELECT CW/CCW F2 01

◆Clockwise : CW (Default)

◆Counter Clockwise : CCW

◆Stop:STOP

Set it to "CCW", in case that ACCU-10 has been installed onto the bottom of the table.







○Setting the delay time between the stop timing for tape feeder and distangle roller. (Default:03)

Item name : DELAY TIME F2 02

◆To make the distangle roller stop slowly, increase the setting value.

◆To make the distangle roller stop rapidly, decrease the setting value.

#### Setting method

1.  Press this switch twice.
2.  /  Select a item.  
MOTOR SPEED  
SELECT CW/CCW  
DELAY TIME
3.  /  Change the setting value.
4.  Finished.

MOTOR SPEED	
F2 00	05

Fig. 4-33

SELECT CW/CCW	
F2 01	CW

Fig. 4-34







DELAY TIME	
F2 02	03

Fig. 4-35

## 4. Operating control panel

### 4.8.5 Using function of detecting tape seams and knots

The function of detecting tape seams and knots is not effective at shipment. To activate this function, perform the following steps. If the type of tape is changed, the function of detecting tape seams and knots needs to be set up again. If not, seams and knots can not be detected correctly.

1.  Set the tension value of process 1 to "999".
2. Remove the tape from the rollers, and release the clamp lever.
3.  Press this switch 4 times.
4.  Switch to "CLAMP LEVER SET".
5.  The setting value will be decided automatically.
6. Set the tape correctly. (Refer to "3.3 Passing tape")
7.  Switch to "TAPE SET".
8.  The setting value will be decided automatically.
9.  Finished.

When a seam or a knot is detected, tape feeding stops. The error messages will be displayed as shown in Fig. 4-40 and the buzzer starts ringing.

**Stop the buzzer by pressing the clamp lever up.**

#### NOTE

For the function of detecting tape seams and knots, because the device reacts to the thickness of tape, flat seams can not be detected.

TAPE SET	
F4 00	999

Fig. 4-36

CLAMP LEVER SET	
F4 01	057 57

Fig. 4-37

TAPE SET	
F4 00	999

Fig. 4-38

TAPE SET	
F4 00	171

Fig. 4-39

M01 TAPE CHECK	
----------------	--

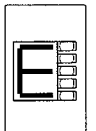



Fig. 4-40

#### NOTE

After performing the steps in "2.5 When tape can not be fed straightly", the function of detecting tape seams and knots needs to be set up again.

Perform the following steps to inactivate the function of detecting seams and knots.

1.  Press this switch 4 times.
2. Press  during the clamp lever is up.  
The setting value will be decided automatically.

TAPE SET	
F4 00	171

Fig. 4-41

TAPE SET	
F4 01	853



Fig. 4-42

### 4.8.6 Correcting detection level for tape seams and knots

If the function of detecting tape seams and knots works unstable, for example, tape seams and knots can not be detected, or the device can detect seams or knots at where no seam or knot exists, correct the setting value.

- If seams or knots can not be detected, decrease the setting value.
- If the device detects seams or knots, even though no seam or knot exists, increase the setting value.

#### Setting method

1.  Press this switch 4 times.
2.  Correct the setting value.
3.  Finished.

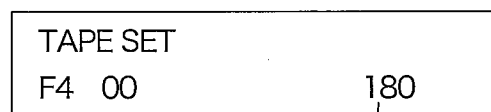

Fig. 4-43

Setting value





## 4.9 Controlling devices on sewing machine

When using devices such as tape cutter, tension releaser or thread chain trimmer with ACCU-10 together, ACCU-10 can control these devices.

#### Attention

Cables, sensors and switches may need to be changed.

The devices that can be controlled by ACCU-10 have been listed in table 1-5. For setting up, perform the following steps.

1.  Press this switch 3 times.
2.  Select a item. (Refer to Table 1-5.)
2.  Change the setting. (Refer to Table 1-5.)
4.  Finished.

#### SUPPLEMENT

Be sure to change the settings in each mode.

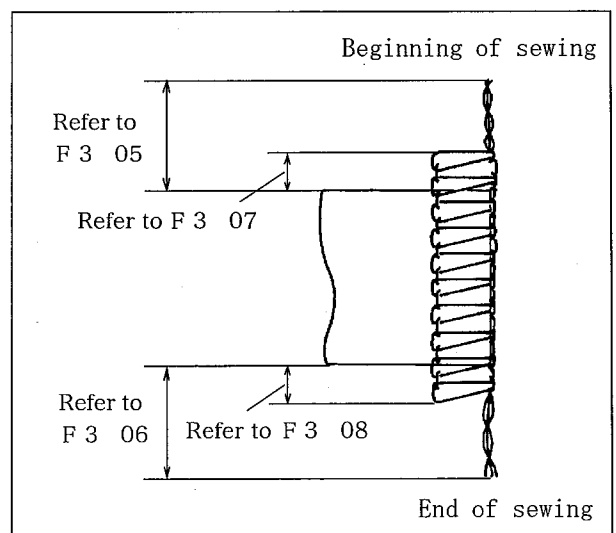

Fig. 4-44 Timing for tape cutting and tension releasing.

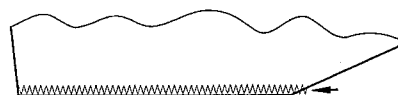

Fig. 4-45 An example of slant fabric.

## 4. Operating Control Panel

### 4.9.1 List of cutter device functions

Item name	Adjustable range	Default	Description
F3 00 FRONT	ON/OFF	OFF	ON: The knife functions at the beginning of sewing. OFF: The knife does not function at the beginning of sewing.
F3 01 FINISH	ON/OFF	OFF	ON: The knife functions at the end of sewing. OFF: The knife does not function at the end of sewing.
F3 03 SLANT FABRIC	ON/OFF	OFF	Make the cutter device function when sewing slant fabrics like Fig. 4-45. ON: In case of sewing slant fabrics, the knife functions at the beginning of sewing even though the fabric detection switch has detected the material. OFF: The knife will not function at the beginning of sewing if the fabric detection switch has detected the material.  <b>⚠ WARNING</b> In case of SLANT FABRIC "ON", the knife also functions when you try to sew the material again.
F3 05 FRONT CUT	000-250	5	The length of the tape at the beginning of sewing. Stitch count by that the knife cuts the tape at the beginning of sewing, after the fabric detection switch starts to detect the material. (Refer to Fig4-44.) To make the length of tape shorter, increase the value. To make the length of tape longer, decrease the value. Do not set the value too high. If not, the material may be cut.
F3 06 FINISH CUT	000-250	30	The length of the tape at the end of sewing. Stitch count by that the knife cuts the tape at the end of sewing, after the fabric detection switch stop detecting the material. (Refer to Fig. 4-44.) To make length of tape shorter, decrease its value. To make length of tape longer, increase its value. Do not set the value too low. If not, the material may be cut.
F3 15 CUTTER TIMER	000-250	70	Operating time of the cutter device. To shorten the operating time of cutter, decrease the value. To extend the operating time of cutter, increase the value. Do not set the value too low. If not, the tape may not be cut.

Table 1

### 4.9.2 List of tension releaser functions

Item name	Adjustable range	Default	Description
F3 07 FRONT TR	000-250	5	Stitch count by that the thread tension releaser tightens the needle thread after fabric detector switch detects the material. (Refer to Fig. 4-44.) If set the value too high, the needle thread may be loosened in the material at the beginning of sewing.
F3 08 FINISH TR	000-250	20	Stitch count by that the thread tension releaser loosens the needle thread after fabric detector switch stops detecting the material. (Refer to Fig. 4-44) If set the value too low, the needle thread may be loosened in the material at the end of sewing.

Table 2

### 4.9.3 List of thread chain trimmer functions

Item name	Adjustable range	Default	Description
F3 09 C DEV OFF	000-250	20	Stitch count before K device stops, after the fabric detection switch detected the material.
F3 10 C DEV ON	000-250	20	Stitch count before K device starts working, after the fabric detection switch stop detecting the material.

Table 3

### 4.9.4 List of lint suction device functions

For overlock machines with SC10 device and interlock stitch machines with right hand trimming knife or left hand trimming knife.

Item name	Adjustable range	Default	Description
F3 11 LINT SUC ON	000-250	20	Stitch count before that the suction pipe starts to suction the lint, after the fabric detection switch detected the material.
F3 12 LINT SUC OFF	000-250	20	Stitch count before that the suction pipe stops suctioning, after the fabric detection switch detected the end of material.

Table 4

### 4.9.5 List of other functions

Item name	Adjustable range	Default	Description
F3 04 RESTART	ON/OFF	OFF	The machine can run without using material. When using AUTO STOP (F3 02) function OFF: The motor will start running after the fabric detection switch detected the material. ON: The motor will start running in either case that the fabric detection switch detected or did not detect the material.
F3 13 MESH TIMER	000-250	0	To prevent malfunction of the knife and the thread tension releaser, increase the value when sewing mesh or lace material.
F3 02 AUTO STOP	ON/OFF	OFF	The motor can be stopped automatically. ON: Using this function. OFF: Not using this function.
F3 14 AUTO STOP TIMER	000-250	50	Stitch count by the motor stops, after the fabric detection switch detected the end of the material. (Note: A motor which can be stopped by external signals need to be used.)
F3 16 AUTO FL DOWN	000-250	50	The timing of lowering the presser foot after the fabric detection switch detected the material.

Table 5

## 4. Operating control panel





### 4.9.6 Function of linking with AZ8451

Perform the steps in “4.10 Control functions” and turn on “AZ8451+”, the functions in Table 6 will be activated.

Item name	Adjustable range	Default	Description
F5 01 BLINK SIZE	00-99	5	Stitch count by that ACCU-10 starts to control the tension of tape, after the tape is inserted under the presser foot and the sewing machine starts running. If the setting is incorrect, the tape may come out of the presser foot when ACCU-10 tightens the
F5 02 DELAY CUT TIME	00-99	0	Time delay between pressing the tape cut switch and the knife cut the tape.

Table 6



#### Setting method

-  Press this switch 5 times.
-  Select a item.
-  Change the setting value.
-  Finished.

### 4.10 Adjusting tension when the presser foot is up

In case that the tension free switch, c. set is equipped, the tape will be without tension when the presser foot is raised up. But, the tension for tape can also be adjusted. Perform the following steps to set the tension.

#### Setting method

-  Press this switch 5 times.
-  Change the setting value. (Default: 999)
-  Finished.

BLINK TENSION	
F5 00	999

Fig. 4-46

- ◆ To increase the tension, set a smaller setting value.
- ◆ To decrease the tension, set a bigger setting value.





## 4.11 Control functions

Control functions and setting method are as below.



Item name	Adjustable range	Default	Description
SENSOR LEVEL			After changing the sensors, electronic boards, and the direction of tape feeder, the base level of tension sensor need to be reset. The setting method has been shown on the lower right of this page.
STYLE NO	ON/OFF	OFF	Do not use this function.
AZ8451+	ON/OFF	OFF	When want to link ACCU 10 with AZ8451, set to "ON".
PEDAL SW TYPE	NC/NO	NO	To set the electric characteristic for tension free switch C. Set. In case of using the parts of Yamato, set the value to "NO".
COUNT PULSE	01~99	1	The number of signals that the rotation detector sends during sewing machine runs for 1 revolution. Set the value to "1" on normal occasion. Set the value to "34" in case of AZ8451 class. Set the value to "35" in case of VF2429, VF2459.
SELECT SWITCH CUTTER	CUTTER/PROCESS	PROCESS	Switch the function from "manual switch" to "knee switch". (Refer to Table 8.)
SENSOR SW TYPE	LIGHT ON/DARK ON	LIGHT ON	Change the logic for fabric detection switch. Set it to "LIGHT ON" on normal occasion.
LANGUAGE	ニホンゴ/ENGLISH	ENGLISH	Switch the language from "Japanese" to "English".
BUZZER PATTERN	0~4	1	The buzzer patterns 0-4 can be selected. The buzzer sounds in each pattern. In case of "0", the buzzer does not sound.

Table 7

### Setting method

-  Hold down this switch for more than 3 seconds.
-  Select a item.
-  Change the setting value.
-  Hold down for more than 3 seconds.  
Finished.

### Setting the base level

- Remove the tape from the tape feeder.
-  Hold down this switch for more than 3 seconds.
-  The setting value will be decided automatically.
-  Hold down this switch for more than 3 seconds.  
Finished.

Switch Setting	Manual switch	Knee switch
PROCESS	Cutter switch	Process shifting switch
CUTTER	Process shifting switch	Cutter switch

Table 8





## 4. Operating control panel

### 4.12 Connection test

The control panel allows you to test the connections of input devices such as switches and output devices such as solenoid valves.

#### 4.12.1 Input test



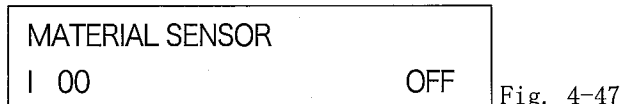

-  Turn the power supply ON while holding down the switch.
-  Press this switch to display the input devices in Table 9.
- Either "ON" or "OFF" is displayed at the right end of the display depending on the current condition of the input device.
- Upon completion of the test, turn OFF the power switch.



Display		Input device
Top part	Lower part	
I 00	MATERIAL SENSOR	Fabric detector
I 01	KNEE SW	Knee SW
I 02	HEEL ON	Tension free SW (toe down)
I 03	HEEL BACK	Tension free SW (heel back)
I 04	HAND SWITCH	Manual SW or cutter SW
I 05	NEEDLE SWITCH	Rotation detector unit
I 06	INPUT 6	Not used
I 07	INPUT 7	Not used
I 08	INPUT 8	Not used
I 09	INPUT 9	Not used
I 10	INPUT 10	Not used
I 11	INPUT 11	Not used

Table 9

#### 4.12.2 Output test

-  Turn ON the power supply while holding down the switch.
- 
-  Press the switch to display the input devices in Table 10.
-  The device is displayed will start to function.
- Upon completion of the test, turn OFF the power switch.

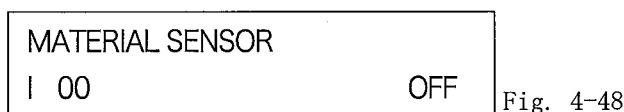

Display		Output device
Top part	Lower part	
O 00	CUTTER	Tape cutter
O 01	C DEV	Thread chain suction
O 02	LINT SUC	Lint suction
O 03	TR	Tesion release
O 04	FOOT LIFT	Press foot lifter
O 05	OUTPUT5	Not used
O 06	OUTPUT6	Not used
O 07	OUTPUT7	Not used
O 08	OUTPUT8	Not used
O 09	OUTPUT9	Not used
O 10	OUTPUT10	Not used
O 11	M MOTOR CW	Motor of tape feeder clockwise
O 12	M MOTOR CCW	Motor of tape feeder counterclockwise
O 13	S MOTOR CW	Motor of distangle roller clockwise
O 14	S MOTOR CCW	Motor of distangle roller counterclockwise

Table 10

### ⚠ CAUTION

Never place finger, hair or objects close to the moving parts while doing connection test.

# 5. Trouble shooting

Error display	Remedy/Action
UNSETTING POWER OFF	[SENSOR LEVEL] has not been set. (Refer to the part "Setting basic level " in "4.11 Control functions ")
E01 POWER OFF	Feeding roller motor② error : repair or exchange the feeding roller motor② or electronic board A. (Refer to the part "Setting basic level " in "4.11 Control functions ")
E02 POWER OFF	Distangle roller motor① error : repair or exchange the distangle roller motor ① or electronic board A. (Refer to the part "Setting basic level " in "4.11 Control functions ")
E03 POWER OFF	Feeding roller motor error② and distangle roller motor①: Repair or exchange both feeding roller motor② and distangle roller motor① or electronic board A. (Refer to the part "Setting basic level " in "4.11 Control functions ")
E04 POWER OFF	Feeding roller motor② error : repair or exchange the feeding roller motor② or electronic board A. (Refer to the part "Setting basic level " in "4.11 Control functions ")
M01 TAPE CHECK	Detecting seams and knots: Check the tape. Press the [CLAMP LEVER] up to silence the buzzer.

Table 11

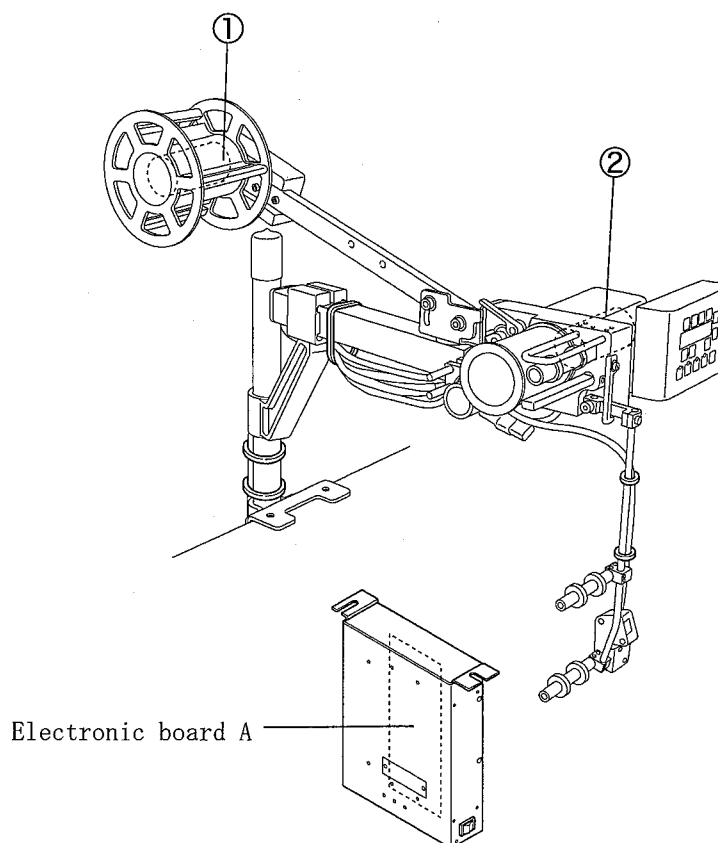

Fig. 5-1

# 6. Specifications

---

Model	ACCU-10
Dimensions	Control box: 270 (L) × 65 (W) × 215 (H) mm
Weight	11 kg
Tape tension adjustable range	0.05-7N
Maximum tape width	75mm
Tape feeding speed	0-42m/min.
Power supply	AC100V-240V 50/60Hz (Automatic change)
Ambient temperature	+5°C~+40°C
Humidity	90% RH or less
Power consumption	200 VA
Output current	Less than 100mA
Saving capacity for settings	8 processes/mode, 50 modes for maximum

# 7. Information

## 7.1 Description of connectors and input signals

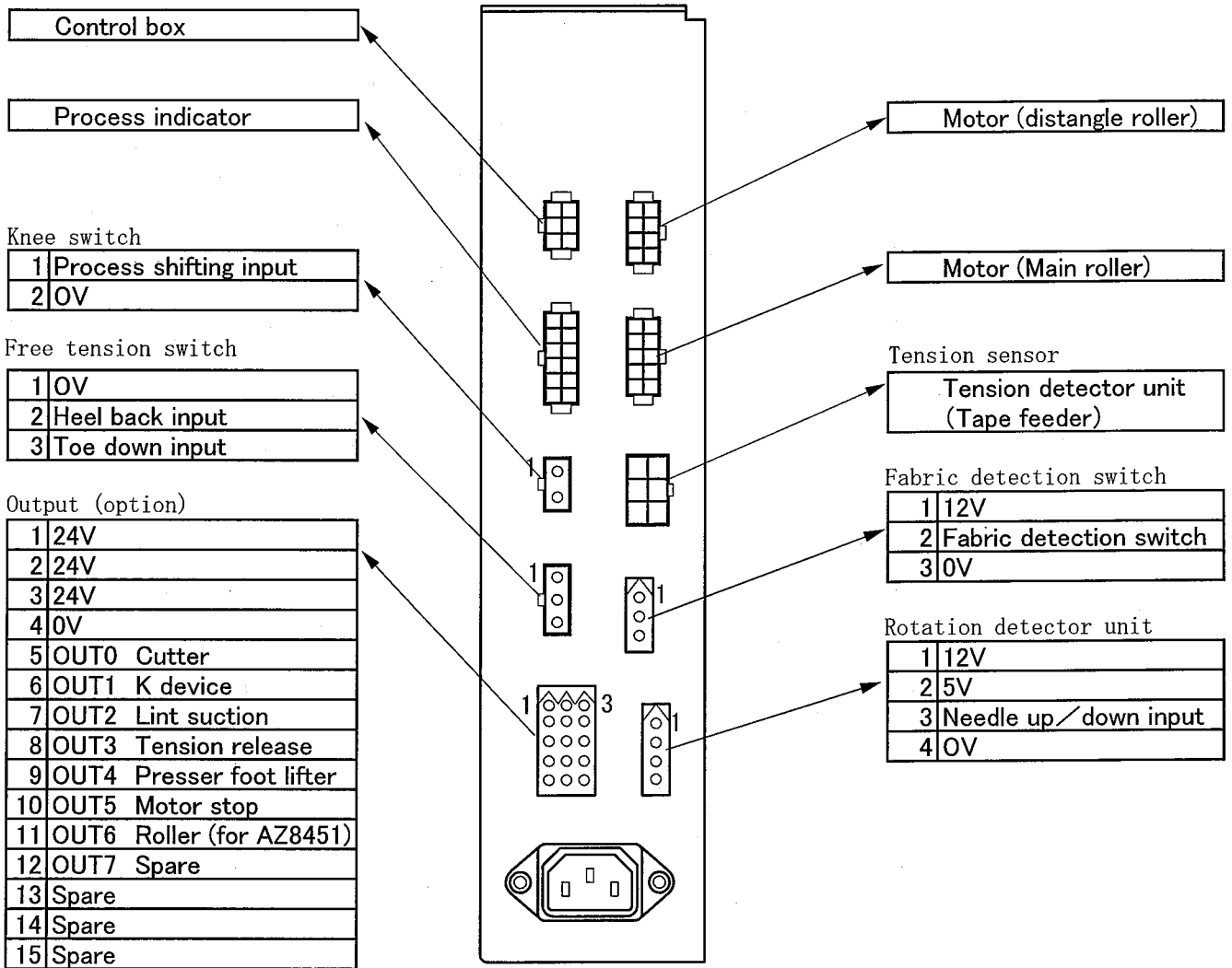
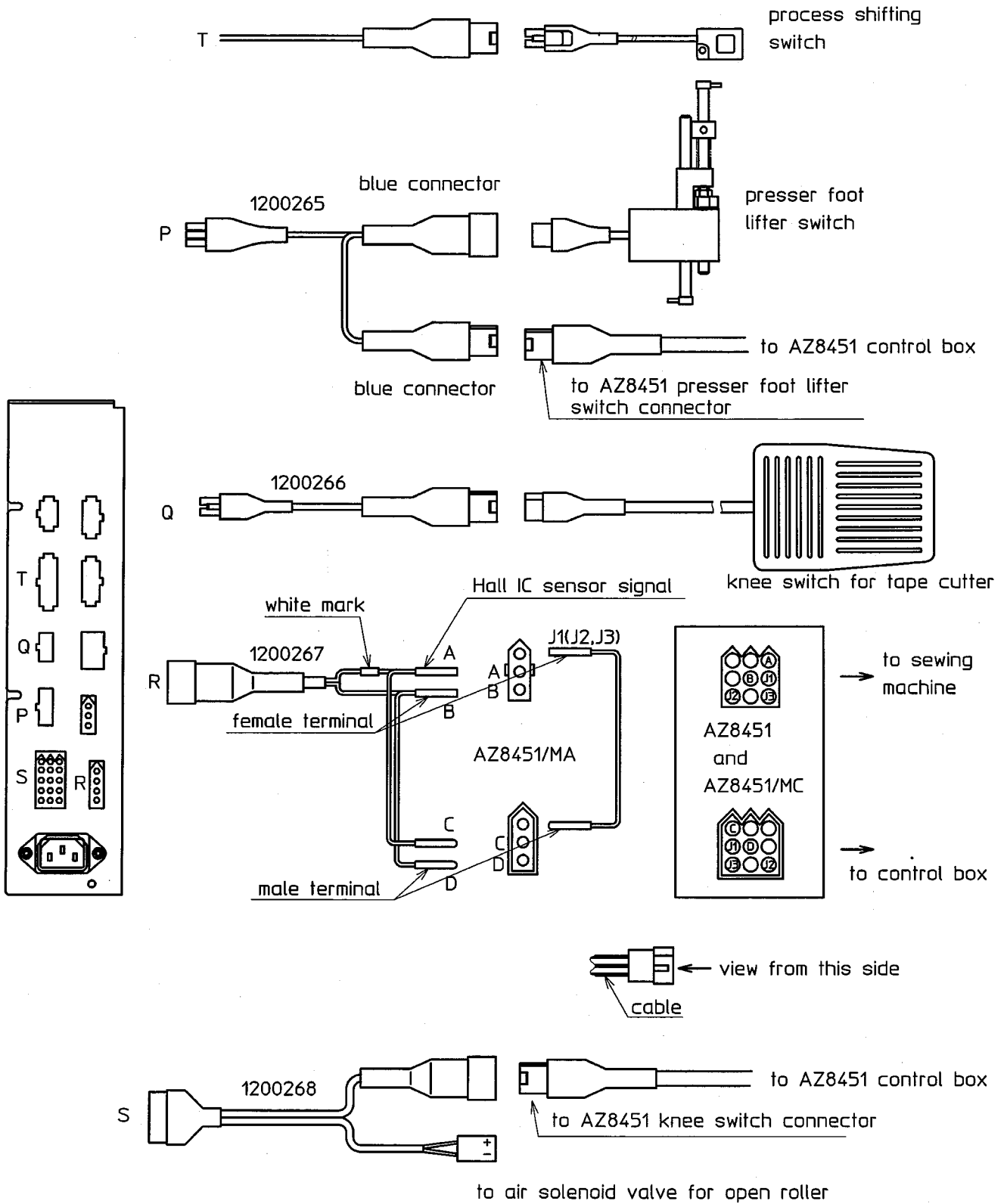

Fig. 7-1

## 7.2 Connecting AZ8451 with ACCU-10-C1T device



***Yamato***

ヤマトマシン製造株式会社

***YAMATO SEWING MACHINE MFG. CO., LTD.***

4-4-12, NISHITENMA, KITA-KU, OSAKA, JAPAN  
TEL : 81-6-6364-1321 FAX : 81-6-6364-1307

〒530-0047 大阪市北区西天満4丁目4番12号  
TEL(06)6364-1321(代) FAX(06)6365-5176